

CASEGOODS

PRICEBOOK



FRIANT AT A GLANCE

COMPONENTS

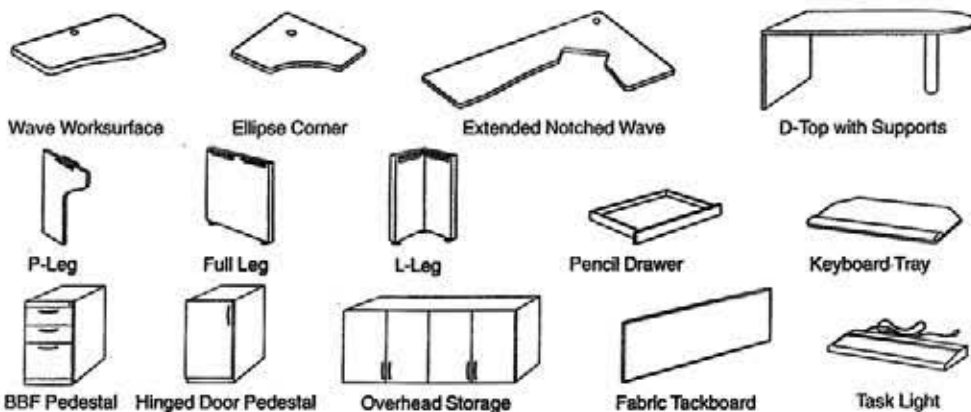
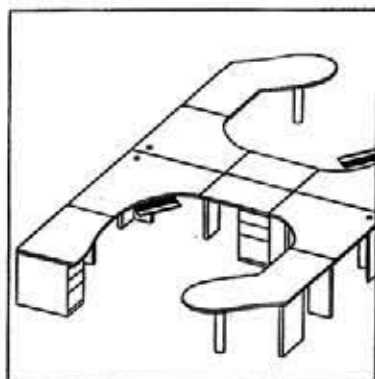

CASEGOODS

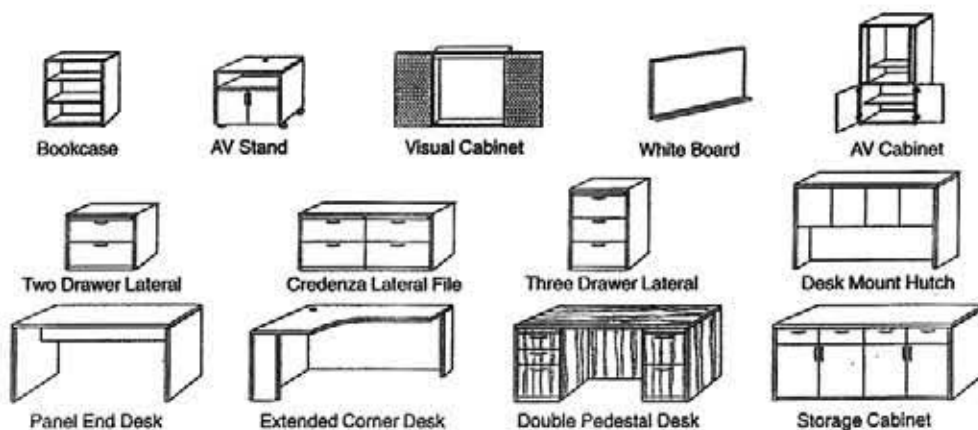
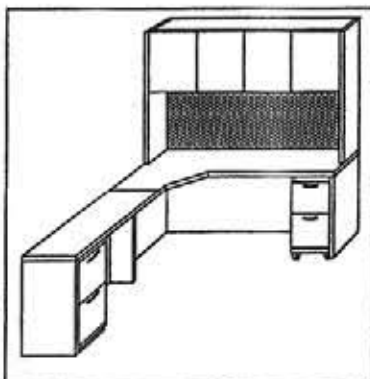

TABLES

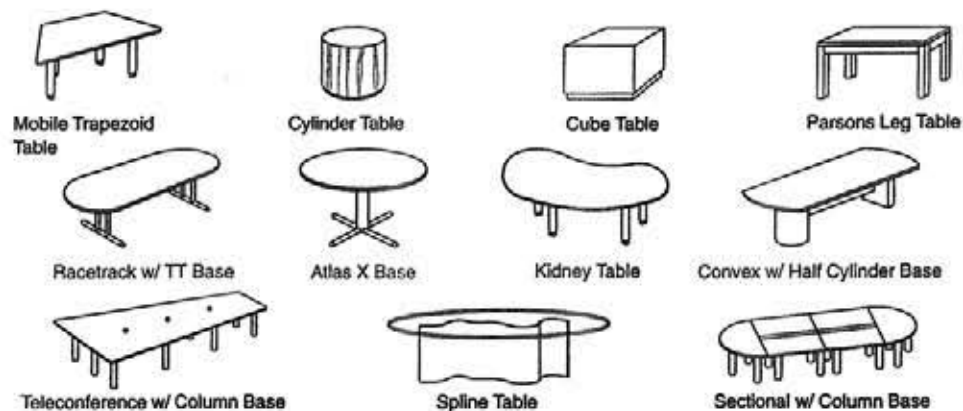
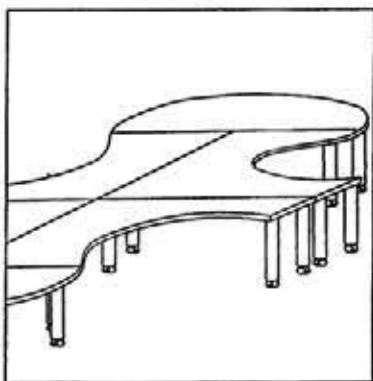

RECEPTION STATONS

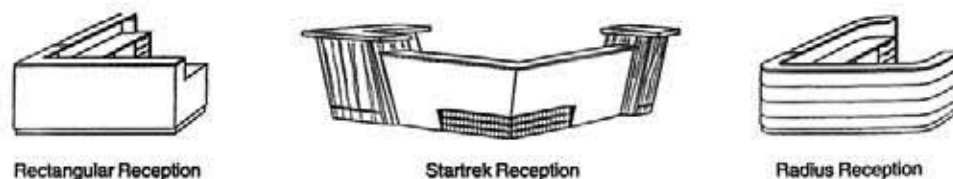
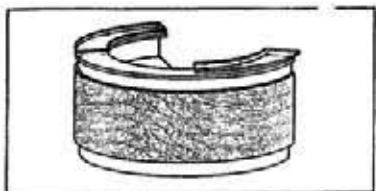

TABLE OF CONTENTS

| | |
|-----------------------------------|-----------|
| GENERAL INFORMATION | 5 |
| Overview of Friant & Price List | |
| Terms & Conditions | |
| Edge Details | |
| Corner Details | |
| Product Specifications & Finishes | |
| COMPONENTS | 15 |
| Worksurfaces & Transaction Tops | |
| Grommet Locations | |
| Support & Modesty Panels | |
| Optional Accessories | |
| Pedestals & Files | |
| Overhead Storage | |
| Tackboards | |
| CASEGOODS | 41 |
| Desks | |
| Returns, Bridges & Corners | |
| Peninsula Desks | |
| Desk Mount Hutches | |
| Bookcases | |
| Lateral Files & Credenzas | |
| Storage Units | |
| Video Cabinets | |
| Visual & White Boards | |
| TABLES | 59 |
| General/Conference Tables | |
| Occasional Tables | |
| RECEPTION STATIONS | 69 |
| Rectangular | |
| Radius Corner | |

GENERAL INFORMATION

3

Terms and Conditions

PRICES

All Prices are F.O.B. point. We reserve the right to change prices without prior notice.

ORDERING

Purchase Orders should be sent to Friant & Associates, LLC at orders@friant.com, or faxed to (510) 535-6895. If your specifications were created with CAP, GIZA or Project Matrix, please send the worksheet (SP4) with your Purchase Order.

TERMS

Net 30 days from date of invoice. Invoices are delinquent if not paid 30 days from date of invoice. In the event timely payment is not made, interest will be charged at the rate of 1.5% per month on delinquent accounts. Buyers will also be liable for normal collection costs and attorney's fee. 50% deposit is required with every order, unless prior arrangements have been made.

ORDERS

Orders are only accepted by issuance of our formal acknowledgment, and are subject to the terms set forth herein and on our order acknowledgment. It is the responsibility of the buyer to review our acknowledgment for accuracy.

SHIPPING

Friant generally palletizes, boxes and/or shrink-wraps its products. If buyer requests additional packaging or special shipping, then it is responsible for any extra costs that result. Buyer obtains title to products and assumes the risk of loss for them upon shipment from Friant's plant.

CLAIMS

We are not responsible for damage suffered in transit. Merchandise should be inspected for possible freight damage upon delivery. The consignee should file for damage or shortages with the carrier within 5 days of delivery. You are also protected for "concealed damage" if you file claim with the carrier within 5 days of delivery. Buyer must make all claims against Friant for defects, errors or shortages in writing within 10 days after delivery. Failure to make such a claim shall constitute full acceptance.

RETURNS

No merchandise may be returned without our written consent and shipping instructions. Unauthorized returns will not be accepted and will be returned freight collect.

PARTIAL SHIPMENTS

We will make every attempt to ship orders complete and on schedule. However, we reserve the right to make partial shipments, as merchandise is ready. Invoices covering these shipments are to be paid as they become due.

ORDER CHANGE — CANCELLATIONS

Our order confirmation is final and binding. Any order change or cancellation is subject to our ability to conform. For the most up to date information, always review the order change/cancellation policy online. Allowable changes within the posted policy must be made in writing.

SHIPMENT AND PREPAID FREIGHT

Unless otherwise instructed, we reserve the option to ship by what is, in our opinion, the best possible way. Upon request, we will prepay and add freight for accounts with established credit.

DELIVERY

We are not liable for delay or failure of delivery due to strikes and/or differences with workmen, war, riot, fire, compliance with government regulations, acts of nature, failure or delays of sources of supply, or any other causes beyond our control.

STORAGE

If buyer cannot accept delivery when merchandise is ready, we reserve the right to transfer goods to storage. Costs of transfer and storage will be charged to the buyer's account, and we will deem such transfer as constituting shipment for all purposes, including invoicing, as of the date the transfer is made.

CONSTRUCTION — SPECIFICATIONS

All items are produced to price list specifications unless otherwise advised. All dimensions shown are approximate. Manufacturer reserves the right to make modifications and/or improvements without prior notice.

FABRIC APPLICATION

Standard fabric application is Non-Directional application. Certain product construction and sizes require fabric to be applied only Directionally or Non-Directionally. See individual pricebook specifications for details.

Friant & Associates is not responsible for charges associated with replacement of products due to incorrect specifications.

CUSTOMER'S OWN MATERIAL Yardage requirement is based on 66" wide plain covering material, and must be increased if less than 66" wide. Special instructions for handling material (pattern, directional fabric, right side of reversible fabric, etc.) must be submitted in writing before fabric is delivered. In the absence of special instructions, we reserve the right to use our own judgment. We reserve the right to reject any covering, which in our opinion, is unsuitable for our upholstery purposes. However, in no instance shall we be held responsible for unsatisfactory results due to use of covering unsuitable for our upholstery methods.

We will not be responsible for errors caused by buyers not supplying us with sample cuttings attached to their order giving full identification of covering material, (name of supplier, covering name, number and color) for identification purposes and advising us of model number and quantity to which each cover is to be applied.

Customer's own material that is shipped freight collect will be refused. A service charge will be applied for the return of unusable C.O.M. Contact factory.

Terms and Conditions continued..

RIGHTS AND WARRANTIES — LIMITED LIFETIME WARRANTY

This warranty is given to the initial purchaser and is valid from the date of purchase, for as long as the initial purchaser owns the product. This warranty covers defects in material and craftsmanship found during normal usage of the product during the warranty period. Normal usage is defined by 8 hour shifts in the product's intended application and in an indoor environment that conforms to the ANSI/ASHRAE Standard 55: Thermal Environmental Conditions for Human Occupancy (relating to air temperature, mean radiant temperature, air velocity, clothing insulation, metabolic rate, and humidity). Friant's warranty does not cover usage other than normal usage as defined in the previous sentence. If the product is defective, and if written notice of the defect is given to Friant & Associates within the applicable warranty period, Friant & Associates, at its option, will either repair or replace the defective product with a comparable component or product. This warranty applies to all products except as noted below.

High wear parts, such as wood veneer, fabrics, and other covering material/finishes, foam, glides, etc. are warranted for one (1) year. This warranty does not apply to damage caused by a carrier, alteration to the product not expressly authorized by Friant & Associates, nor to product considered to be of a consumable nature such as bulbs, light ballasts, etc. It also does not apply to "Customer's Own Material" (i.e. material specified by the customer that is not a standard Friant & Associates offering) used in the manufacture of Friant & Associates products.

Our warranty for LED lights is 2 years.

Friant & Associates does not warrant the matching of colors, grain or texture, except to within commercially acceptable standards.

This includes normal variations between dye lots (fabrics).

A product will not be considered defective, and Friant & Associates will not be obligated to replace it, if it is not installed in a proper manner (i.e. product not leveled, not secured properly, etc.) or if it is not used in a manner and/or in an environment that constitutes normal usage, as defined above.

Except as noted above, Friant & Associates makes no express or implied warranties to any product, and in particular makes no warranty of fitness for any particular use. At Friant & Associates' option, product repair and replacement is the customer's exclusive remedy for any and all product defects.

Friant & Associates shall not be liable for consequential, economic, or incidental damages arising from any product defect.

CALIFORNIA PROP 65 WARNING

Products in this catalog can expose you to chemicals including wood dust, which is known to the State of California to cause cancer or birth defects or other reproductive harm. For more information go to <https://www.p65warnings.ca.gov/products/furniture-products>."

CARB

Friant products are CARB 93120 compliant for formaldehyde (phase 2)

TSCA Title VI

Friant products are TSCA Title VI Compliant

MAS

Accredited Compliance Designation - ANSI/BIFMA x7.1 & e3-2014 7.6.1, 7.6.2, 7.6.3
California Dept. Of Public Health Standard Method v1.2
Conforms With: LEED v4
Criteria of MAS Certified Green ® Program

EDGE DETAILS

The following edge details are available on all products in this catalog. Prices in each section are based on Group Number, actual edge within each Group must be specified.

GROUP 1 - LAMINATE TOP

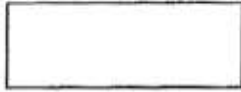

Laminate Self Edge
1 1/4" Thick

GROUP 2 - LAMINATE TOP

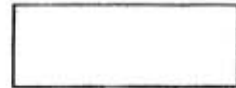

3mm PVC Edge
1 1/4" Thick

GROUP 3 - LAMINATE TOP

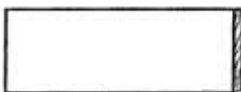

1/4" Wood Eased Edge
1 1/4" Thick

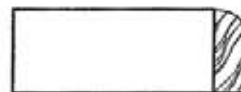

1/2" Wood Radius Edge
1 1/4" Thick

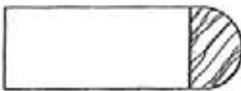

3/4" Wood Bullnose Edge
1 1/4" Thick

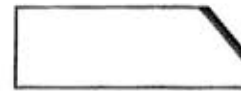

3/4" Black Reveal Bevel Edge
1 1/4" Thick

GROUP 4 - VENEER TOP



Veneer
1/4" Wood Eased Edge
1 1/4" Thick



Veneer
1/2" Wood Radius Edge
1 1/4" Thick

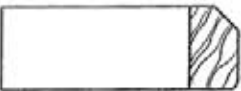

Veneer
3/4" Wood Bevel Edge
1 1/4" Thick

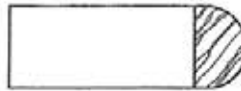

Veneer
3/4" Wood Bullnose Edge *
1 1/4" Thick

**Note: not available on all products.*

EDGE DETAILS - CONFERENCE TABLES

The following edge details are available on conference tables only. Prices in each section are based on Group Number, actual edge within each Group must be specified.

GROUP 1 - LAMINATE TOP

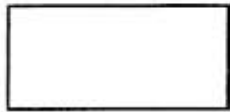

Laminate Self Edge
1 1/4" Thick

GROUP 2 - LAMINATE TOP

GROUP 3 - LAMINATE TOP

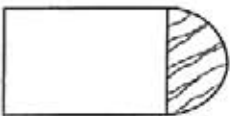

Bullnose Wood Edge
1" Wide x 1 1/4" Thick

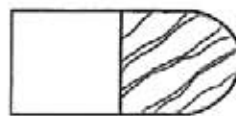

Bullnose Wood Edge
1 1/4" Wide x 1 1/4" Thick
5% upcharge

GROUP 5 - VENEER TOP

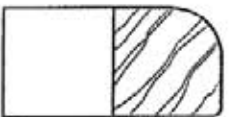

Veneer
Radius Wood Edge
1 1/4" Wide x 1 1/4" Thick

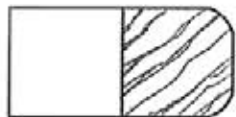

Veneer
Double Radius Wood Edge
1 1/4" Wide x 1 1/4" Thick

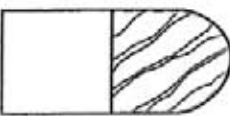

Veneer
Bullnose Wood Edge
1 1/4" Wide x 1 1/4" Thick

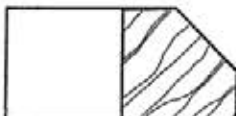

Veneer
Bevel Wood Edge
1 1/4" Wide x 1 1/4" Thick

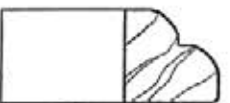

Veneer
Double Radius Wood Edge
1 1/4" Wide x 1 1/4" Thick

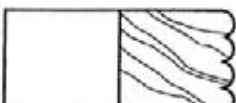

Veneer
Beaded Wood Edge
1 1/4" Wide x 1 1/4" Thick



Veneer
Knife Wood Edge
1 1/4" Wide x 1 1/4" Thick

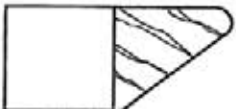

Veneer
Reverse Knife Wood Edge
1 1/4" Wide x 1 1/4" Thick

CORNER DETAILS - CASEGOODS

The following drawings show the corner details for each Group Number and Edge design. Top design and end panel design are identified in each drawing. On all of the series, except as noted, the end panel continues to the floor with no extra base detail. Adjustable glides complete the unit.

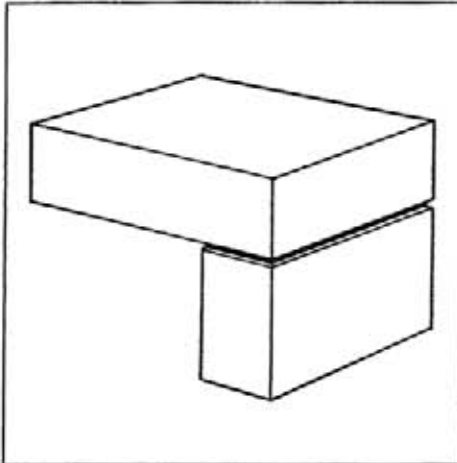

Group 1 - Laminate Self Edge Top & End Panel, 1 1/4" Thick

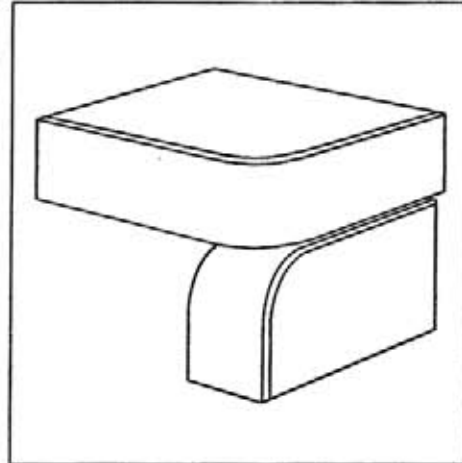

Group 1 - Laminate Top & End Panel with Vinyl T-Mold Edge, 1 1/4" Thick

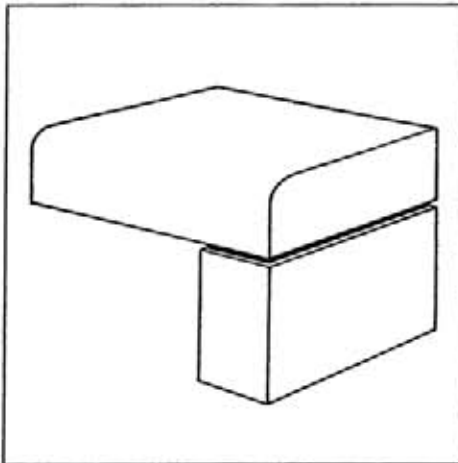

Group 2 - Laminate Top with Postform Edge & Self Edge End Panel, 1 1/4" Thick

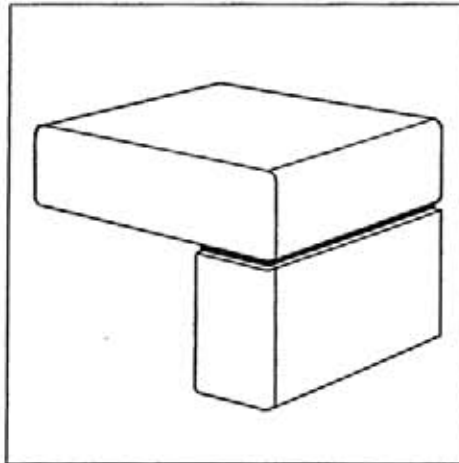

Group 2 - Laminate Top with 3mm PVC Edge & Self Edge End Panel, 1 1/4" Thick

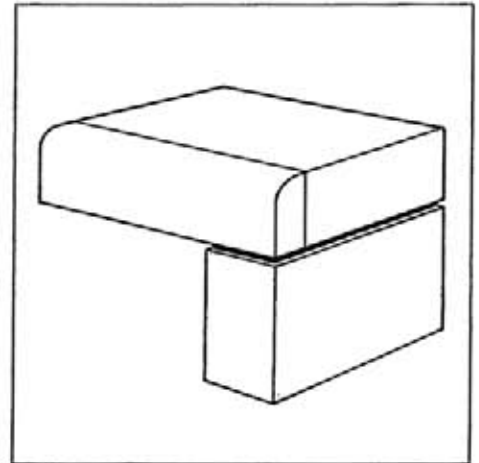

Group 2 - Laminate Top with Comfort T-Mold Edge & Self Edge End Panel, 1 1/4" Thick

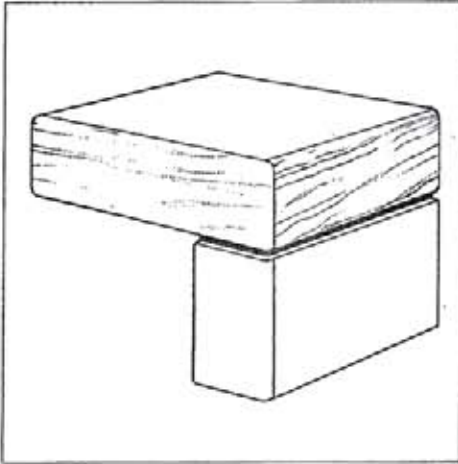

Group 3 - Laminate Top & End Panel with 1/4" Wood Eased Edge, 1 1/4" Thick

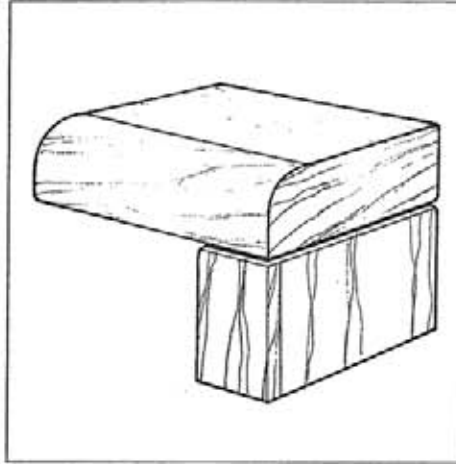

Group 3 - Laminate Top with 1/2" Wood Radius Edge & Laminate End Panel with 1/4" Wood Eased Edge, 1 1/4" Thick

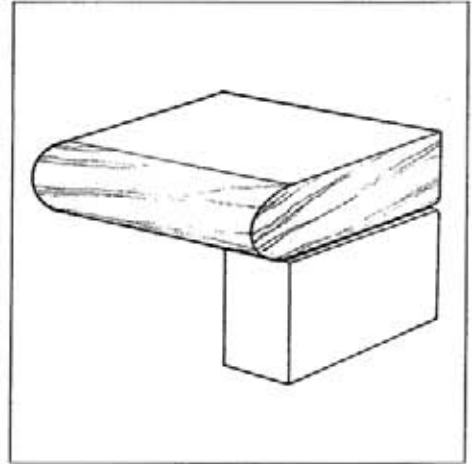

Group 3 - Laminate Top with 3/4" Wood Bullnose Edge & Self Edge End Panel, 1 1/4" Thick

Group 4 - Veneer Top & End Panel with 1/4" Wood Eased Edge, 1 1/4" Thick

Group 4 - Veneer Top with 1/2" Wood Radius Edge & Veneer End Panel with 1/4" Wood Eased Edge, 1 1/4" Thick

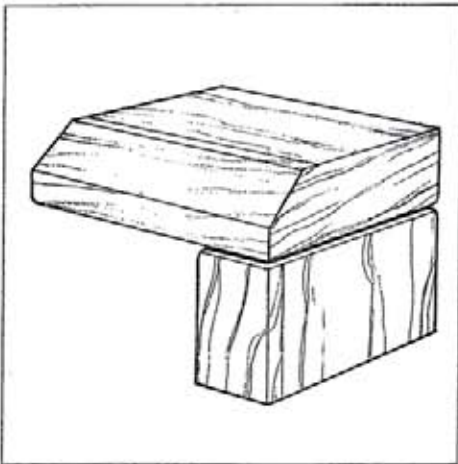

Group 4 - Veneer Top with 1/2" Wood Bevel Edge & Veneer End Panel with 1/4" Wood Eased Edge, 1 1/4" Thick

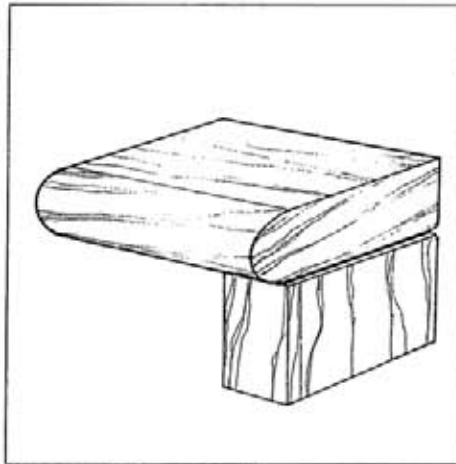

Group 4 - Veneer Top with 3/4" Wood Bullnose Edge & Veneer End Panel with 1/4" Wood Eased Edge, 1 1/4" Thick

PRODUCT SPECIFICATIONS

COMPONENTS OVERVIEW

The components section offers worksurfaces and supports available in a wide range of sizes and shapes. Components can be designed to meet specifications of various major O.E.M. sources (see below) for use in both new and used configurations. These worksurfaces are also suitable for generic systems use or can be adapted to fit with the systems products of other manufacturers. Also, because pedestals and modesty panels are available, full freestanding units can be built from the components found here.

When specifying components please use the following O.E.M. Manufacturer Codes: H.W. - Haworth; H.M. - Herman Miller; A.S. - AllSteel; S.C. - Steelcase; H.N. - Hon and T.N. - Teknion. (Company names are registered trademarks and are not associated with Friant.) These parts are authorized only by Friant and originate with Friant. Specifications are subject to change without notice.

Worksurfaces and supports can be made compatible with any other furniture system. Simply state manufacturer to be matched.

For orders of 50 or more worksurfaces, call the factory for pricing. Custom sizes and shapes are available. Contact the factory for assistance.

SPECIFICATIONS

LAMINATE SPECIFICATIONS & FINISHES

Friant uses 45lb density 1-1/8" industrial grade particle board. Our horizontal worksurfaces are finished with high pressure laminate on top and high pressure backing sheet on bottom. Particle board build-up is applied to increase thickness of tops when necessary.

Friant offers solid and woodgrain laminates with a "textured" finish by Wilsonart, Nevamar, Formica, and Pionite. Most colors and patterns are standard. Please consult factory to verify availability.

"Gloss" laminates have a high sheen, glass-like finish that is very susceptible to scratching. Gloss finishes require more expensive material and additional labor costs. Please consult factory for further information.

Laminates by other manufacturers are available and may be subject to additional costs. Call the factory for more information.

Note: Because Friant does not manufacture the high pressure laminates used in our products, we are subject to product modifications and price increases by the laminate manufacturer.

VENEER SPECIFICATIONS & FINISHES

Friant's standard veneers and solid hardwoods are White Oak, Walnut, Cherry and Maple. Other veneers, such as Rift Oak, Ribbon Mahogany, Birdseye, or special woodgrains are also available. Call the factory for pricing.

Please call the factory for information on special wood stains and finishes.

PRODUCT SPECIFICATIONS

SPECIFICATIONS, continued

DRAWER SPECIFICATIONS

Drawer bodies consist of ½" particle board core with black vinyl surface and mitre fold construction. As an option, maple hardwood with dowel construction and a clear lacquer finish is available.

Veneer and laminate wood grain drawer faces are vertically matched, individually and across desks and credenzas.

Box Drawers:

- 3½" inside height x 15⅞", 21", or 25⅞" deep (depending on overall depth of pedestal).
- Equipped with Accuride suspensions.
- Adjustable drawer divider included.
- Pencil tray included in top box drawer.

File Drawers:

- 9" inside height x 15⅞", 21", or 25⅞" deep (depending on overall depth of pedestal).
- Pedestals are letter size with 12¼" inside width.
- Side-to-side pendaflex filing is standard, front-to-back filing is available. Call factory for pricing.

Lateral Files:

- All lateral file drawers have 15⅞" inside depth, no matter the overall depth of file.
- Pendaflex filing

KEYBOARD MECHANISMS

Standard Adjustable Keyboard Arm:

Weber Knapp Micro Arm #14915

ClickIt Adjustable Keyboard Arm:

ClickIt is the latest "intuitive" keyboard arm, one hand...one motion raises it to working height. No knobs or levers to release, nothing in the kneespace to tear your clothes or bang your knees. ClickIt offers over 10° of vertical adjustment, putting you into compliance with the newest ANSI/HFS-100 specifications. ClickIt's tray adjusts for positive/negative tilt, to help keep the wrists straight, and can be shifted left/right of center to keep the user centered on the arm for unparalleled stability. ClickIt is spring-assisted: it feels light as a feather in your hand and never drops into your lap.

- Height: 10.3"
- Tilt: ±15° (will become ±10°)
- Lateral: 4" (will become 5")
- Fully retracts on track as short as 18"

KEY LOCKS/ CORES

Casegoods locking storage uses the LAM3 series locks. LAM3 locks are available. They are sold separately through the Willow catalog. Please see Willow Pricebook for part numbers and pricing.

CUSTOMS

All custom work is welcomed. Please call the factory.



COMPONENTS

STRAIGHT WORKSURFACES

| MODEL NUMBER | SIZE D x W | WT. | EDGE DETAILS | | | |
|-----------------|---------------|-----|--------------|---------|---------|---------|
| | | | GROUP 1 | GROUP 2 | GROUP 3 | GROUP 4 |
| STRAIGHT | | | | | | |
| WS 2024 | 20 x 24 | 17 | 100 | 140 | 190 | 275 |
| WS 2030 | 20 x 30 | 21 | 105 | 145 | 216 | 308 |
| WS 2036 | 20 x 36 | 25 | 110 | 150 | 250 | 347 |
| WS 2048 | 20 x 48 | 33 | 120 | 160 | 270 | 445 |
| WS 2060 | 20 x 60 | 42 | 135 | 175 | 343 | 525 |
| WS 2072 | 20 x 72 | 50 | 160 | 200 | 375 | 550 |
| WS 2096 | 20 x 96 | 67 | 210 | 285 | 606 | 700 |
| WS 20120 | 20 x 120 | 83 | 265 | 365 | 750 | 850 |
| WS 20144 | 20 x 144 | 100 | 375 | 475 | 875 | 1000 |
| WS 2424 | 24 x 24 | 20 | 100 | 140 | 200 | 275 |
| WS 2430 | 24 x 30 | 25 | 105 | 145 | 235 | 290 |
| WS 2436 | 24 x 36 | 30 | 110 | 150 | 260 | 325 |
| WS 2448 | 24 x 48 | 40 | 120 | 160 | 300 | 445 |
| WS 2460 | 24 x 60 | 50 | 135 | 175 | 352 | 525 |
| WS 2472 | 24 x 72 | 60 | 160 | 200 | 410 | 550 |
| WS 2496 | 24 x 96 | 80 | 250 | 285 | 620 | 700 |
| WS 24120 | 24 x 120 | 100 | 275 | 390 | 775 | 850 |
| WS 24144 | 24 x 144 | 120 | 395 | 475 | 847 | 1000 |
| WS 3024 | 30 x 24 | 25 | 105 | 170 | 240 | 315 |
| WS 3030 | 30 x 30 | 31 | 115 | 170 | 265 | 375 |
| WS 3036 | 30 x 36 | 38 | 120 | 175 | 296 | 410 |
| WS 3048 | 30 x 48 | 50 | 140 | 185 | 345 | 468 |
| WS 3060 | 30 x 60 | 63 | 175 | 225 | 385 | 565 |
| WS 3072 | 30 x 72 | 75 | 200 | 250 | 525 | 665 |
| WS 3096 | 30 x 96 | 100 | 275 | 350 | 730 | 880 |
| WS 30120 | 30 x 120 | 125 | 325 | 435 | 860 | 1000 |
| WS 30144 | 30 x 144 | 150 | 425 | 510 | 1060 | 1200 |

WHEN ORDERING SPECIFY

- MODEL NUMBER & DESCRIPTION, INCLUDING OPTIONS
- SIZE
- EDGE DETAIL
- GROMMET LOCATION
- FINISH
- OEM MANUFACTURER, IF APPLICABLE

NOTES & OPTIONS

- PRICE & ORDER SUPPORTS SEPARATELY
- INTERMEDIATE SIZES - PRICE AT NEXT LARGEST SIZE, SPECIFY AND CHANGE MODEL NUMBER
- FOR 36" DEEP WORKSURFACES ADD 20% TO 30" DEEP PRICES
- FRIANT MANUFACTURES TOPS SIZED TO FIT ANY OEM SYSTEM, PLEASE SPECIFY WHICH SYSTEM (SEE PAGE 12)

STRAIGHT WORKSURFACES

EDGE DETAILS

| MODEL NUMBER | SIZE D x W | WT. | EDGE DETAILS | | | |
|--------------|---------------|-----|--------------|---------|---------|---------|
| | | | GROUP 1 | GROUP 2 | GROUP 3 | GROUP 4 |

SHAPED STRAIGHT WORKSURFACES

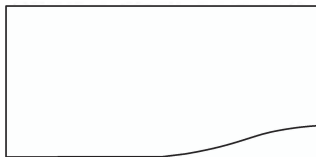

Wave

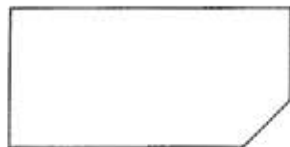

Clipped Corner



Double Clipped Corner

| | | | | | | |
|-----------|----------|-----|-----|-----|------|------|
| SWS 2424 | 24 x 24 | 17 | 110 | 150 | 210 | 320 |
| SWS 2430 | 24 x 30 | 21 | 115 | 160 | 250 | 360 |
| SWS 2436 | 24 x 36 | 25 | 120 | 165 | 288 | 400 |
| SWS 2448 | 24 x 48 | 33 | 132 | 175 | 330 | 440 |
| SWS 2460 | 24 x 60 | 42 | 145 | 190 | 405 | 550 |
| SWS 2472 | 24 x 72 | 50 | 175 | 220 | 439 | 600 |
| SWS 2496 | 24 x 96 | 67 | 275 | 313 | 700 | 800 |
| SWS 24120 | 24 x 120 | 83 | 300 | 420 | 920 | 986 |
| SWS 24144 | 24 x 144 | 100 | 410 | 522 | 1000 | 1160 |
| SWS 3024 | 30 x 24 | 20 | 115 | 160 | 250 | 335 |
| SWS 3030 | 30 x 30 | 25 | 125 | 175 | 285 | 375 |
| SWS 3036 | 30 x 36 | 30 | 130 | 180 | 325 | 410 |
| SWS 3048 | 30 x 48 | 40 | 150 | 190 | 350 | 510 |
| SWS 3060 | 30 x 60 | 50 | 190 | 230 | 431 | 675 |
| SWS 3072 | 30 x 72 | 60 | 220 | 235 | 570 | 900 |
| SWS 3096 | 30 x 96 | 80 | 300 | 360 | 750 | 1050 |
| SWS 30120 | 30 x 120 | 100 | 350 | 425 | 1025 | 1160 |
| SWS 30144 | 30 x 144 | 120 | 450 | 535 | 1100 | 1350 |

Specify design of worksurface.

WHEN ORDERING SPECIFY

- MODEL NUMBER & DESCRIPTION, INCLUDING OPTIONS
- SIZE
- EDGE DETAIL
- GROMMET LOCATION
- FINISH
- OEM MANUFACTURER, IF APPLICABLE

NOTES & OPTIONS

- PRICE & ORDER SUPPORTS SEPARATELY
- INTERMEDIATE SIZES - PRICE AT NEXT LARGEST SIZE, SPECIFY AND CHANGE MODEL NUMBER
- FOR 36" DEEP WORKSURFACES ADD 20% TO 30" DEEP PRICES
- FRIANT MANUFACTURES TOPS SIZED TO FIT ANY OEM SYSTEM, PLEASE SPECIFY WHICH SYSTEM (SEE PAGE 12)

CORNER WORKSURFACES

| MODEL NUMBER | SIZE D x W | WT. | EDGE DETAILS | | | |
|--------------|---------------|-----|--------------|---------|---------|---------|
| | | | GROUP 1 | GROUP 2 | GROUP 3 | GROUP 4 |

ANGLED CORNER



| | | | | | | |
|-----------|---------|-----|-----|-----|-----|-----|
| ACWS 3636 | 36 x 36 | 41 | 160 | 200 | 350 | 385 |
| ACWS 4242 | 42 x 42 | 53 | 220 | 250 | 375 | 412 |
| ACWS 4848 | 48 x 48 | 70 | 250 | 260 | 388 | 426 |
| ACWS 6060 | 60 x 60 | 109 | 345 | 385 | 561 | 617 |

Dimensions of sides that connect with other worksurfaces need to be specified. Standard sizes are 20", 24", and 30". Please specify both the left side dimension and the right side dimension.

Optional keyboard cutout shown, not included in price - add \$60 list.

CURVED CORNER



| | | | | | | |
|-----------|---------|-----|-----|-----|-----|-----|
| CCWS 3636 | 36 x 36 | 41 | 175 | 205 | 420 | 517 |
| CCWS 4242 | 42 x 42 | 53 | 230 | 265 | 470 | 575 |
| CCWS 4848 | 48 x 48 | 70 | 250 | 265 | 470 | 575 |
| CCWS 6060 | 60 x 60 | 109 | 345 | 385 | 595 | 720 |

Dimensions of sides that connect with other worksurfaces need to be specified. Standard sizes are 20", 24", and 30". Please specify both the left side dimension and the right side dimension.

WHEN ORDERING SPECIFY

- MODEL NUMBER & DESCRIPTION, INCLUDING OPTIONS
- SIZE
- EDGE DETAIL
- GROMMET LOCATION
- FINISH
- OEM MANUFACTURER, IF APPLICABLE

NOTES & OPTIONS

- PRICE & ORDER SUPPORTS SEPARATELY
- INTERMEDIATE SIZES - PRICE AT NEXT LARGEST SIZE, SPECIFY AND CHANGE MODEL NUMBER
- OPTIONAL KEYBOARD CUTOUT AVAILABLE ON ALL CORNER WORKSURFACES - ADD \$60 LIST & SPECIFY
- FRIANT MANUFACTURES TOPS SIZED TO FIT ANY OEM SYSTEM, PLEASE SPECIFY WHICH SYSTEM (SEE PAGE 12)

CORNER WORKSURFACES

| MODEL NUMBER | SIZE D x W | WT. | EDGE DETAILS | | | |
|--------------|---------------|-----|--------------|---------|---------|---------|
| | | | GROUP 1 | GROUP 2 | GROUP 3 | GROUP 4 |

ELIPSE CORNER

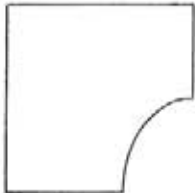

| | | | | | | |
|-----------|---------|-----|-----|-----|-----|-----|
| ECWS 3636 | 36 x 36 | 41 | 175 | 205 | 420 | 517 |
| ECWS 4242 | 42 x 42 | 53 | 230 | 265 | 470 | 575 |
| ECWS 4848 | 48 x 48 | 70 | 250 | 265 | 470 | 575 |
| ECWS 6060 | 60 x 60 | 109 | 345 | 385 | 595 | 720 |

Dimensions of sides that connect with other worksurfaces need to be specified. Standard sizes are 20", 24", and 30". Please specify both the left side dimension and the right side dimension.

NOTCHED CORNER

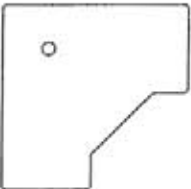

| | | | | | | |
|-----------|---------|-----|-----|-----|-----|-----|
| NCWS 3636 | 36 x 36 | 41 | 175 | 205 | 420 | 517 |
| NCWS 4242 | 42 x 42 | 53 | 230 | 265 | 470 | 575 |
| NCWS 4848 | 48 x 48 | 70 | 250 | 265 | 470 | 575 |
| NCWS 6060 | 60 x 60 | 109 | 345 | 385 | 595 | 720 |

Dimensions of sides that connect with other worksurfaces need to be specified. Standard sizes are 20", 24", and 30". Please specify both the left side dimension and the right side dimension.

WHEN ORDERING SPECIFY

- MODEL NUMBER & DESCRIPTION, INCLUDING OPTIONS
- SIZE
- EDGE DETAIL
- GROMMET LOCATION
- FINISH
- OEM MANUFACTURER, IF APPLICABLE

NOTES & OPTIONS

- PRICE & ORDER SUPPORTS SEPARATELY
- INTERMEDIATE SIZES - PRICE AT NEXT LARGEST SIZE, SPECIFY AND CHANGE MODEL NUMBER
- OPTIONAL KEYBOARD CUTOUT AVAILABLE ON ALL CORNER WORKSURFACES - ADD \$60 LIST & SPECIFY
- FRIANT MANUFACTURES TOPS SIZED TO FIT ANY OEM SYSTEM, PLEASE SPECIFY WHICH SYSTEM (SEE PAGE 12)

EXTENDED CORNER WORKSURFACES

| MODEL NUMBER | SIZE D x W | WT. | EDGE DETAILS | | | |
|--------------|---------------|-----|--------------|---------|---------|---------|
| | | | GROUP 1 | GROUP 2 | GROUP 3 | GROUP 4 |

EXTENDED ANGLED CORNER



Right Extension Shown

| | | | | | | |
|------------|---------|-----|-----|-----|-----|------|
| EACWS 3660 | 36 x 60 | 57 | 235 | 275 | 480 | 590 |
| EACWS 3672 | 36 x 72 | 66 | 275 | 300 | 550 | 695 |
| EACWS 3696 | 36 x 96 | 82 | 390 | 450 | 600 | 800 |
| EACWS 4248 | 42 x 48 | 57 | 250 | 265 | 440 | 600 |
| EACWS 4260 | 42 x 60 | 65 | 285 | 345 | 550 | 685 |
| EACWS 4272 | 42 x 72 | 74 | 315 | 357 | 600 | 775 |
| EACWS 4296 | 42 x 96 | 90 | 530 | 630 | 800 | 980 |
| EACWS 4860 | 48 x 60 | 80 | 285 | 350 | 550 | 785 |
| EACWS 4872 | 48 x 72 | 90 | 395 | 475 | 620 | 900 |
| EACWS 4896 | 48 x 96 | 110 | 530 | 640 | 900 | 1040 |

Dimensions of sides that connect with other worksurfaces need to be specified. Standard sizes are 20°, 24°, and 30°. Please specify both the left side dimension and the right side dimension.

Specify right extension or left extension. Add -R or -L to model number.

WHEN ORDERING SPECIFY

- MODEL NUMBER & DESCRIPTION, INCLUDING OPTIONS
- SIZE
- EDGE DETAIL
- GROMMET LOCATION
- FINISH
- OEM MANUFACTURER, IF APPLICABLE

NOTES & OPTIONS

- PRICE & ORDER SUPPORTS SEPARATELY
- INTERMEDIATE SIZES - PRICE AT NEXT LARGEST SIZE, SPECIFY AND CHANGE MODEL NUMBER
- OPTIONAL KEYBOARD CUTOUT AVAILABLE ON ALL CORNER WORKSURFACES - ADD \$60 LIST & SPECIFY
- FRIANT MANUFACTURES TOPS SIZED TO FIT ANY OEM SYSTEM, PLEASE SPECIFY WHICH SYSTEM (SEE PAGE 12)

EXTENDED CORNER WORKSURFACES

| MODEL NUMBER | SIZE D x W | WT. | EDGE DETAILS | | | |
|--------------|---------------|-----|--------------|---------|---------|---------|
| | | | GROUP 1 | GROUP 2 | GROUP 3 | GROUP 4 |

EXTENDED NOTCHED CORNER

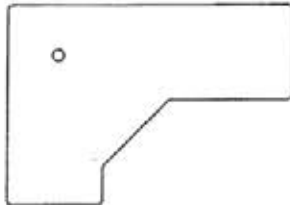

Right Extension Shown

| | | | | | | |
|------------|---------|-----|-----|-----|------|------|
| ENCWS 4248 | 42 x 48 | 53 | 250 | 300 | 520 | 637 |
| ENCWS 4260 | 42 x 60 | 61 | 320 | 390 | 535 | 685 |
| ENCWS 4272 | 42 x 72 | 70 | 335 | 418 | 600 | 775 |
| ENCWS 4296 | 42 x 96 | 86 | 530 | 645 | 750 | 980 |
| ENCWS 4860 | 48 x 60 | 76 | 320 | 400 | 550 | 685 |
| ENCWS 4872 | 48 x 72 | 86 | 385 | 462 | 630 | 800 |
| ENCWS 4896 | 48 x 96 | 106 | 530 | 635 | 900 | 1040 |
| ENCWS 6072 | 60 x 72 | 106 | 550 | 635 | 900 | 1110 |
| ENCWS 6096 | 60 x 96 | 126 | 650 | 785 | 1100 | 1250 |

Dimensions of sides that connect with other worksurfaces need to be specified. Standard sizes are 20", 24", and 30". Please specify both the left side dimension and the right side dimension.

Specify right extension or left extension. Add -R or -L to model number.

WHEN ORDERING SPECIFY

- MODEL NUMBER & DESCRIPTION, INCLUDING OPTIONS
- SIZE
- EDGE DETAIL
- GROMMET LOCATION
- FINISH
- OEM MANUFACTURER, IF APPLICABLE

NOTES & OPTIONS

- PRICE & ORDER SUPPORTS SEPARATELY
- INTERMEDIATE SIZES - PRICE AT NEXT LARGEST SIZE, SPECIFY AND CHANGE MODEL NUMBER
- OPTIONAL KEYBOARD CUTOUT AVAILABLE ON ALL CORNER WORKSURFACES - ADD \$60 LIST & SPECIFY
- FRIANT MANUFACTURES TOPS SIZED TO FIT ANY OEM SYSTEM, PLEASE SPECIFY WHICH SYSTEM (SEE PAGE 12)

EXTENDED CORNER WORKSURFACES

| MODEL NUMBER | SIZE D x W | WT. | EDGE DETAILS | | | |
|--------------|---------------|-----|--------------|---------|---------|---------|
| | | | GROUP 1 | GROUP 2 | GROUP 3 | GROUP 4 |

EXTENDED CURVED CORNER

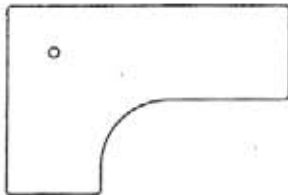

Right Extension Shown

| | | | | | | |
|------------|---------|-----|-----|-----|------|------|
| ECCWS 4260 | 42 x 60 | 61 | 320 | 390 | 630 | 822 |
| ECCWS 4272 | 42 x 72 | 70 | 335 | 418 | 700 | 930 |
| ECCWS 4296 | 42 x 96 | 86 | 530 | 645 | 860 | 1176 |
| ECCWS 4860 | 48 x 60 | 70 | 320 | 410 | 630 | 822 |
| ECCWS 4872 | 48 x 72 | 78 | 385 | 465 | 700 | 930 |
| ECCWS 4896 | 48 x 96 | 95 | 530 | 635 | 860 | 1176 |
| ECCWS 6072 | 60 x 72 | 100 | 550 | 650 | 900 | 1332 |
| ECCWS 6096 | 60 x 96 | 115 | 650 | 785 | 1100 | 1500 |

Dimensions of sides that connect with other worksurfaces need to be specified. Standard sizes are 20", 24", and 30". Please specify both the left side dimension and the right side dimension.

Specify right extension or left extension. Add -R or -L to model number.

WHEN ORDERING SPECIFY

- MODEL NUMBER & DESCRIPTION, INCLUDING OPTIONS
- SIZE
- EDGE DETAIL
- GROMMET LOCATION
- FINISH
- OEM MANUFACTURER, IF APPLICABLE

NOTES & OPTIONS

- PRICE & ORDER SUPPORTS SEPARATELY
- INTERMEDIATE SIZES - PRICE AT NEXT LARGEST SIZE, SPECIFY AND CHANGE MODEL NUMBER
- OPTIONAL KEYBOARD CUTOUT AVAILABLE ON ALL CORNER WORKSURFACES - ADD \$60 LIST & SPECIFY
- FRIANT MANUFACTURES TOPS SIZED TO FIT ANY OEM SYSTEM, PLEASE SPECIFY WHICH SYSTEM (SEE PAGE 12)

EXTENDED CORNER WORKSURFACES

| MODEL NUMBER | SIZE D x W | WT. | EDGE DETAILS | | | |
|--------------|---------------|-----|--------------|---------|---------|---------|
| | | | GROUP 1 | GROUP 2 | GROUP 3 | GROUP 4 |

EXTENDED ELIPSE CORNER

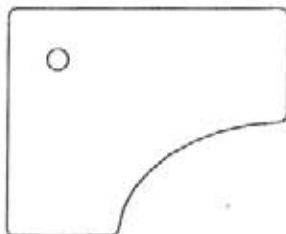

Right Extension Shown

| | | | | | | |
|------------|---------|-----|-----|-----|------|------|
| EECWS 4260 | 42 x 60 | 61 | 320 | 390 | 630 | 822 |
| EECWS 4272 | 42 x 72 | 70 | 335 | 418 | 700 | 930 |
| EECWS 4296 | 42 x 96 | 86 | 530 | 645 | 860 | 1176 |
| EECWS 4860 | 48 x 60 | 70 | 320 | 410 | 630 | 822 |
| EECWS 4872 | 48 x 72 | 78 | 385 | 465 | 700 | 930 |
| EECWS 4896 | 48 x 96 | 95 | 530 | 645 | 860 | 1176 |
| EECWS 6072 | 60 x 72 | 100 | 550 | 650 | 900 | 1332 |
| EECWS 6096 | 60 x 96 | 115 | 650 | 785 | 1100 | 1500 |

Dimensions of sides that connect with other worksurfaces need to be specified. Standard sizes are 20", 24", and 30". Please specify both the left side dimension and the right side dimension.

Specify right extension or left extension. Add -R or -L to model number.

WHEN ORDERING SPECIFY

- MODEL NUMBER & DESCRIPTION, INCLUDING OPTIONS
- SIZE
- EDGE DETAIL
- GROMMET LOCATION
- FINISH
- OEM MANUFACTURER, IF APPLICABLE

NOTES & OPTIONS

- PRICE & ORDER SUPPORTS SEPARATELY
- INTERMEDIATE SIZES - PRICE AT NEXT LARGEST SIZE, SPECIFY AND CHANGE MODEL NUMBER
- OPTIONAL KEYBOARD CUTOUT AVAILABLE ON ALL CORNER WORKSURFACES - ADD \$60 LIST & SPECIFY
- FRIANT MANUFACTURES TOPS SIZED TO FIT ANY OEM SYSTEM, PLEASE SPECIFY WHICH SYSTEM (SEE PAGE 12)

PENINSULA WORKSURFACES

EDGE DETAILS

| MODEL NUMBER | SIZE D x W | WT. | EDGE DETAILS | | | |
|----------------|---------------|-----|--------------|---------|---------|---------|
| | | | GROUP 1 | GROUP 2 | GROUP 3 | GROUP 4 |
| D SHAPE | | | | | | |
| DT 2436 | 24 x 36 | 30 | 147 | 190 | 500 | 800 |
| DT 2448 | 24 x 48 | 40 | 158 | 200 | 540 | 845 |
| DT 2460 | 24 x 60 | 50 | 180 | 215 | 573 | 895 |
| DT 2472 | 24 x 72 | 60 | 210 | 246 | 617 | 930 |
| DT 2496 | 24 x 96 | 80 | 280 | 310 | 650 | 960 |
| DT 3036 | 30 x 36 | 38 | 170 | 200 | 565 | 869 |
| DT 3048 | 30 x 48 | 50 | 180 | 220 | 575 | 890 |
| DT 3060 | 30 x 60 | 63 | 210 | 252 | 617 | 929 |
| DT 3072 | 30 x 72 | 75 | 225 | 275 | 663 | 1000 |
| DT 3096 | 30 x 96 | 100 | 330 | 365 | 721 | 1040 |
| DT 3660 | 36 x 60 | 75 | 230 | 275 | 682 | 960 |
| DT 3672 | 36 x 72 | 90 | 300 | 336 | 715 | 990 |
| DT 3696 | 36 x 96 | 120 | 400 | 430 | 819 | 1133 |

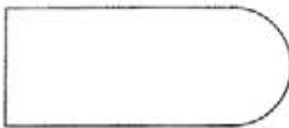

WHEN ORDERING SPECIFY

- MODEL NUMBER & DESCRIPTION, INCLUDING OPTIONS
- SIZE
- EDGE DETAIL
- GROMMET LOCATION
- FINISH
- OEM MANUFACTURER, IF APPLICABLE

NOTES & OPTIONS

- PRICE & ORDER SUPPORTS SEPARATELY
- INTERMEDIATE SIZES - PRICE AT NEXT LARGEST SIZE, SPECIFY AND CHANGE MODEL NUMBER
- FRIANT MANUFACTURES TOPS SIZED TO FIT ANY OEM SYSTEM, PLEASE SPECIFY WHICH SYSTEM (SEE PAGE 12)

PENINSULA WORKSURFACES

EDGE DETAILS

| MODEL NUMBER | SIZE D/Radius x W | WT. | EDGE DETAILS | | | |
|--------------|----------------------|-----|--------------|---------|---------|---------|
| | | | GROUP 1 | GROUP 2 | GROUP 3 | GROUP 4 |

P SHAPE

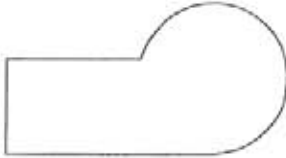

Right Extension Shown

| | | | | | | |
|------------|------------|-----|-----|-----|------|------|
| PT 24/3666 | 24/36 x 66 | 70 | 330 | 396 | 1025 | 1280 |
| PT 24/3672 | 24/36 x 72 | 75 | 330 | 396 | 1025 | 1280 |
| PT 24/3696 | 24/36 x 96 | 95 | 410 | 490 | 1220 | 1475 |
| PT 30/4266 | 30/42 x 66 | 86 | 385 | 465 | 1010 | 1350 |
| PT 30/4272 | 30/42 x 72 | 92 | 385 | 465 | 1010 | 1350 |
| PT 30/4296 | 30/42 x 96 | 117 | 550 | 600 | 1400 | 1600 |
| PT 36/4872 | 36/48 x 72 | 110 | 385 | 465 | 1010 | 1380 |
| PT 36/4896 | 36/48 x 96 | 140 | 588 | 705 | 1010 | 1630 |
| PT 36/5496 | 36/54 x 96 | 154 | 700 | 840 | 1870 | 2100 |
| PT 36/6096 | 36/60 x 96 | 170 | 700 | 840 | 1870 | 2100 |

Specify right extension or left extension. Add -R or -L to model number.

WHEN ORDERING SPECIFY

- MODEL NUMBER & DESCRIPTION, INCLUDING OPTIONS
- SIZE
- EDGE DETAIL
- GROMMET LOCATION
- FINISH
- OEM MANUFACTURER, IF APPLICABLE

NOTES & OPTIONS

- PRICE & ORDER SUPPORTS SEPARATELY
- INTERMEDIATE SIZES - PRICE AT NEXT LARGEST SIZE, SPECIFY AND CHANGE MODEL NUMBER
- FRIANT MANUFACTURES TOPS SIZED TO FIT ANY OEM SYSTEM, PLEASE SPECIFY WHICH SYSTEM (SEE PAGE 12)

PENINSULA WORKSURFACES

| MODEL NUMBER | SIZE D/D2 x W | WT. | EDGE DETAILS | | | |
|--------------|------------------|-----|--------------|---------|---------|---------|
| | | | GROUP 1 | GROUP 2 | GROUP 3 | GROUP 4 |

THUMB SHAPE

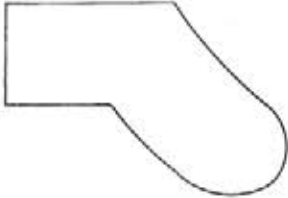

Right Extension Shown

| | | | | | | |
|------------|------------|-----|-----|-----|------|------|
| TM 24/3666 | 24/36 x 66 | 70 | 400 | 440 | 1200 | 1350 |
| TM 24/3672 | 24/36 x 72 | 75 | 450 | 475 | 1200 | 1400 |
| TM 24/3696 | 24/36 x 96 | 95 | 500 | 550 | 1375 | 1550 |
| TM 30/4266 | 30/42 x 66 | 86 | 410 | 450 | 1220 | 1380 |
| TM 30/4272 | 30/42 x 72 | 92 | 470 | 515 | 1220 | 1380 |
| TM 30/4296 | 30/42 x 96 | 117 | 525 | 575 | 1400 | 1600 |

Specify right extension or left extension. Add -R or -L to model number.

Dimensions measured as shown below:

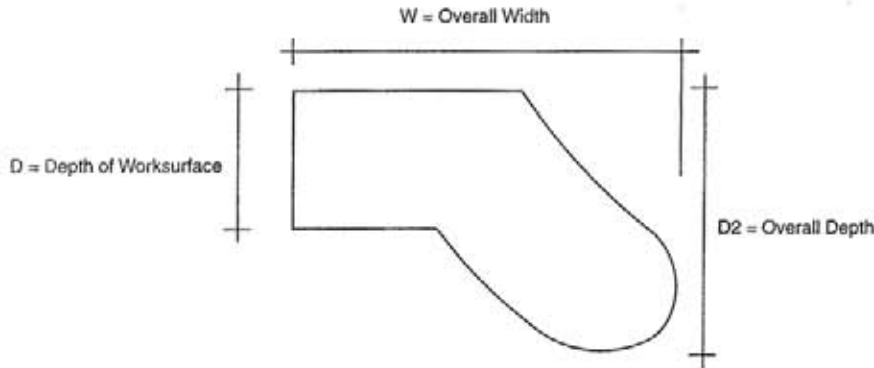

WHEN ORDERING SPECIFY

- MODEL NUMBER & DESCRIPTION, INCLUDING OPTIONS
- SIZE
- EDGE DETAIL
- GROMMET LOCATION
- FINISH
- OEM MANUFACTURER, IF APPLICABLE

NOTES & OPTIONS

- PRICE & ORDER SUPPORTS SEPARATELY
- INTERMEDIATE SIZES - PRICE AT NEXT LARGEST SIZE, SPECIFY AND CHANGE MODEL NUMBER
- FRIANT MANUFACTURES TOPS SIZED TO FIT ANY OEM SYSTEM, PLEASE SPECIFY WHICH SYSTEM (SEE PAGE 12)

PENINSULA WORKSURFACES

| MODEL NUMBER | SIZE D/Radius x W | WT. | EDGE DETAILS | | | |
|----------------|----------------------|-----|--------------|---------|---------|---------|
| | | | GROUP 1 | GROUP 2 | GROUP 3 | GROUP 4 |
| J SHAPE | | | | | | |
| JT 24/3666 | 24/36 x 66 | 70 | 330 | 396 | 1080 | 1280 |
| JT 24/3672 | 24/36 x 72 | 75 | 330 | 396 | 1080 | 1280 |
| JT 24/3696 | 24/36 x 96 | 95 | 410 | 490 | 1250 | 1475 |
| JT 30/4266 | 30/42 x 66 | 86 | 385 | 465 | 1111 | 1350 |
| JT 30/4272 | 30/42 x 72 | 92 | 385 | 465 | 1111 | 1350 |
| JT 30/4296 | 30/42 x 96 | 117 | 550 | 600 | 1385 | 1600 |
| JT 36/4872 | 36/48 x 72 | 110 | 385 | 465 | 1111 | 1380 |
| JT 36/4896 | 36/48 x 96 | 140 | 588 | 705 | 1385 | 1630 |
| JT 36/5496 | 36/54 x 96 | 154 | 700 | 840 | 1890 | 2000 |
| JT 36/6096 | 36/60 x 96 | 170 | 700 | 840 | 1890 | 2000 |



Right Extension Shown

Specify right extension or left extension. Add -R or -L to model number.

WHEN ORDERING SPECIFY

- MODEL NUMBER & DESCRIPTION, INCLUDING OPTIONS
- SIZE
- EDGE DETAIL
- GROMMET LOCATION
- FINISH
- OEM MANUFACTURER, IF APPLICABLE

NOTES & OPTIONS

- PRICE & ORDER SUPPORTS SEPARATELY
- INTERMEDIATE SIZES - PRICE AT NEXT LARGEST SIZE, SPECIFY AND CHANGE MODEL NUMBER
- FRIANT MANUFACTURES TOPS SIZED TO FIT ANY OEM SYSTEM, PLEASE SPECIFY WHICH SYSTEM (SEE PAGE 12)

EXTENDED PENINSULA WORKSURFACES

| MODEL NUMBER | SIZE D x W | WT. | EDGE DETAILS | | | |
|--------------|---------------|-----|--------------|---------|---------|---------|
| | | | GROUP 1 | GROUP 2 | GROUP 3 | GROUP 4 |

EXTENDED CURVED CORNER D SHAPE

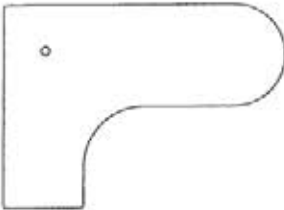

Right Extension Shown

| | | | | | | |
|-------------|---------|-----|-----|-----|------|------|
| EDCCWS 4860 | 48 x 60 | 65 | 420 | 460 | 900 | 1250 |
| EDCCWS 4872 | 48 x 72 | 84 | 446 | 500 | 1100 | 1325 |
| EDCCWS 4896 | 48 x 96 | 117 | 525 | 575 | 1350 | 1700 |
| EDCCWS 6072 | 60 x 72 | 110 | 525 | 575 | 1450 | 1700 |
| EDCCWS 6096 | 60 x 96 | 135 | 665 | 720 | 1620 | 2000 |

Dimension of side that connects with another work surface needs to be specified. Depth of bullet top also needs to be specified. Standard sizes are 20", 24", and 30".

36" and 42" depths available, specify and call factory for pricing.

Specify right extension or left extension. Add -R or -L to model number.

WHEN ORDERING SPECIFY

- MODEL NUMBER & DESCRIPTION, INCLUDING OPTIONS
- SIZE
- EDGE DETAIL
- GROMMET LOCATION
- FINISH
- OEM MANUFACTURER, IF APPLICABLE

NOTES & OPTIONS

- PRICE & ORDER SUPPORTS SEPARATELY
- INTERMEDIATE SIZES - PRICE AT NEXT LARGEST SIZE, SPECIFY AND CHANGE MODEL NUMBER
- FRIANT MANUFACTURES TOPS SIZED TO FIT ANY OEM SYSTEM, PLEASE SPECIFY WHICH SYSTEM (SEE PAGE 12)

CURVED WORKSURFACES

| MODEL NUMBER | SIZE | WT. | EDGE DETAILS | | | |
|--------------|------|-----|--------------|---------|---------|---------|
| | | | GROUP 1 | GROUP 2 | GROUP 3 | GROUP 4 |

QUARTER CIRCLE

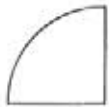

| | | | | | | |
|---------|---------|----|-----|-----|-----|-----|
| WSQC 24 | 24 x 24 | 20 | 130 | 165 | 300 | 400 |
| WSQC 30 | 30 x 30 | 33 | 135 | 165 | 300 | 400 |
| WSQC 36 | 36 x 36 | 47 | 160 | 190 | 400 | 450 |

HALF CIRCLE



| | | | | | | |
|-----------|---------|----|-----|-----|-----|-----|
| HCWS 2448 | 24 x 48 | 43 | 160 | 235 | 490 | 570 |
| HCWS 2460 | 24 x 60 | 53 | 200 | 250 | 500 | 600 |
| HCWS 3060 | 30 x 60 | 64 | 210 | 250 | 520 | 610 |
| HCWS 3072 | 30 x 72 | 77 | 225 | 285 | 550 | 665 |

WHEN ORDERING SPECIFY

- MODEL NUMBER & DESCRIPTION, INCLUDING OPTIONS
- SIZE
- EDGE DETAIL
- GROMMET LOCATION
- FINISH
- OEM MANUFACTURER, IF APPLICABLE

NOTES & OPTIONS

- PRICE & ORDER SUPPORTS SEPARATELY
- INTERMEDIATE SIZES - PRICE AT NEXT LARGEST SIZE, SPECIFY AND CHANGE MODEL NUMBER
- FRIANT MANUFACTURES TOPS SIZED TO FIT ANY OEM SYSTEM, PLEASE SPECIFY WHICH SYSTEM (SEE PAGE 12)

TRANSACTION TOPS

EDGE DETAILS

| MODEL NUMBER | SIZE D x W | WT. | EDGE DETAILS | | | |
|---------------------------------|---------------|-----|--------------|---------|---------|---------|
| | | | GROUP 1 | GROUP 2 | GROUP 3 | GROUP 4 |
| STRAIGHT TRANSACTION TOP | | | | | | |
| CTS 1524 | 15 x 24 | 13 | 85 | 125 | 300 | 425 |
| CTS 1530 | 15 x 30 | 17 | 90 | 130 | 310 | 450 |
| CTS 1536 | 15 x 36 | 19 | 95 | 135 | 350 | 475 |
| CTS 1548 | 15 x 48 | 26 | 105 | 145 | 400 | 500 |
| CTS 1560 | 15 x 60 | 32 | 120 | 160 | 425 | 575 |
| CTS 1572 | 15 x 72 | 38 | 140 | 180 | 475 | 625 |
| CTS 1596 | 15 x 96 | 51 | 200 | 265 | 600 | 675 |

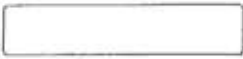

Optional Radius End Top

12" deep counter tops available. Specify and change model number. No upcharge
For radius end top add 30%.

L TRANSACTION TOP

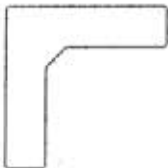

| | | | | | | |
|-------|--------------|----|-----|-----|-----|-----|
| CS 30 | 12 x 30 x 30 | 21 | 160 | 205 | 500 | 600 |
| CS 36 | 12 x 36 x 36 | 25 | 160 | 205 | 500 | 600 |
| CS 42 | 12 x 42 x 42 | 31 | 220 | 260 | 575 | 700 |
| CS 48 | 12 x 48 x 48 | 35 | 220 | 260 | 575 | 700 |
| CS 60 | 12 x 60 x 60 | 45 | 340 | 357 | 700 | 865 |

WHEN ORDERING SPECIFY

- MODEL NUMBER & DESCRIPTION, INCLUDING OPTIONS
- SIZE
- EDGE DETAIL
- FINISH
- OEM MANUFACTURER, IF APPLICABLE

NOTES & OPTIONS

- PRICE & ORDER SUPPORTS SEPARATELY
- INTERMEDIATE SIZES - PRICE AT NEXT LARGEST SIZE, SPECIFY AND CHANGE MODEL NUMBER
- FRIANT MANUFACTURES TOPS SIZED TO FIT ANY OEM SYSTEM, PLEASE SPECIFY WHICH SYSTEM (SEE PAGE 12)

GROMMET LOCATIONS

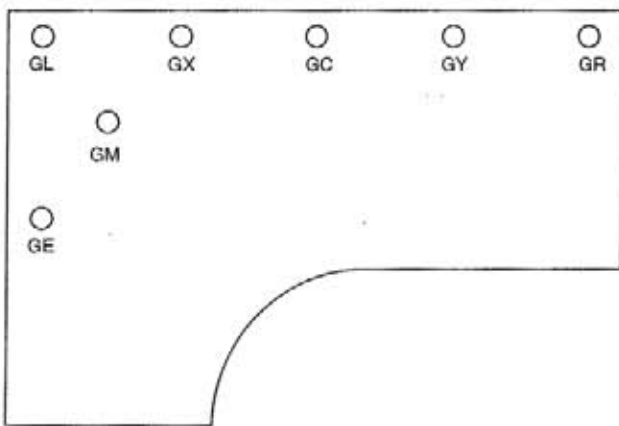
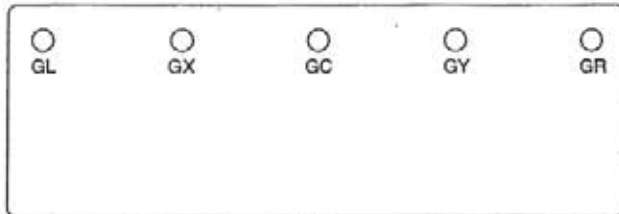

LEGEND

Refer to the illustrations at left for all standard grommet locations.

A 3" round grommet with cover is standard.
GC is standard location unless otherwise specified.

Specify positioning as follows:

Common Combinations

- G1 Pair of grommets at locations GL and GR
- G2 Pair of grommets at locations GL and GC
- G3 Pair of grommets at locations GC and GR
- G4 Pair of grommets at locations GX and GY
- G5 Three grommets at locations GL, GC and GR

Code Position

| Code | Position |
|------|---|
| GL | 4" from left side - 4" from rear |
| GR | 4" from right side - 4" from rear |
| GC | Centered side to side - 4" from rear |
| GX | Centered between GL and GC positions - 4" from rear |
| GY | Centered between GC and GR positions - 4" from rear |
| GM | 12" from each side |
| GE | Centered front to back - 4" from side |

Dimensions are measured from grommet center to top edge.

Note: For other grommet locations call factory for pricing.

Standard grommet finishes are: black, dark grey, light grey, and beige.

WORKSURFACE SUPPORT PANELS

| MODEL NUMBER | SIZE D x H | WT. | OPTIONS | | |
|--------------|---------------|-----|---------|----------|--------|
| | | | BLACK | LAMINATE | VENEER |

FULL LEG

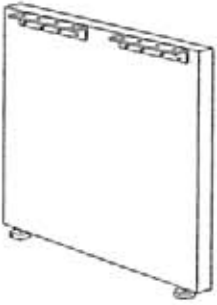

| | | | | | |
|----------|-----------------------|----|-----|-----|-----|
| WSP 2029 | 20 x 27 $\frac{3}{4}$ | 19 | 90 | 145 | 265 |
| WSP 2429 | 24 x 27 $\frac{3}{4}$ | 23 | 100 | 165 | 265 |
| WSP 3029 | 30 x 27 $\frac{3}{4}$ | 29 | 115 | 175 | 275 |
| WSP 3629 | 36 x 27 $\frac{3}{4}$ | 33 | 130 | 195 | 300 |

These supports are used to create a freestanding unit. Use support panels at ends of worksurfaces or where they connect. When support panels are used where two worksurfaces connect, a mending plate is required.

P LEG



| | | | | | |
|----------|-----------------------|----|-----|-----|-----|
| PSP 2029 | 20 x 27 $\frac{3}{4}$ | 19 | 90 | 145 | 300 |
| PSP 2429 | 24 x 27 $\frac{3}{4}$ | 23 | 100 | 165 | 300 |
| PSP 3029 | 30 x 27 $\frac{3}{4}$ | 29 | 115 | 175 | 315 |
| PSP 3629 | 36 x 27 $\frac{3}{4}$ | 33 | 130 | 195 | 345 |

These supports are used to create a freestanding unit. Use support panels at ends of worksurfaces or where they connect. When support panels are used where two worksurfaces connect, a mending plate is required.

WHEN ORDERING SPECIFY

- MODEL NUMBER & DESCRIPTION, INCLUDING OPTIONS
- SIZE
- EDGE DETAIL
- FINISH
- OEM MANUFACTURER, IF APPLICABLE

NOTES & OPTIONS

- FRIANT MANUFACTURES SUPPORTS SIZED TO FIT ANY OEM SYSTEM, PLEASE SPECIFY WHICH SYSTEM (SEE PAGE 12)

WORKSURFACE SUPPORT PANELS

| MODEL NUMBER | SIZE D x H | WT. | OPTIONS | | |
|--------------|---------------|-----|---------|----------|--------|
| | | | BLACK | LAMINATE | VENEER |

C LEG

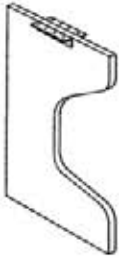

| | | | | | |
|----------|-----------------------|----|-----|-----|-----|
| CSP 2029 | 20 x 27 $\frac{3}{4}$ | 19 | 90 | 145 | 300 |
| CSP 2429 | 24 x 27 $\frac{3}{4}$ | 23 | 100 | 165 | 300 |
| CSP 3029 | 30 x 27 $\frac{3}{4}$ | 29 | 115 | 175 | 315 |
| CSP 3629 | 36 x 27 $\frac{3}{4}$ | 33 | 130 | 195 | 345 |

These supports are used to create a freestanding unit. Use support panels at ends of worksurfaces or where they connect. When support panels are used where two worksurfaces connect, a mending plate is required.

HALF LEG



| | | | | | |
|----------|-----------------------|----|----|-----|-----|
| HSP 1229 | 12 x 27 $\frac{3}{4}$ | 12 | 75 | 95 | 195 |
| HSP 1529 | 15 x 27 $\frac{3}{4}$ | 15 | 85 | 120 | 225 |

These supports are used to create a freestanding unit. Use support panels at ends of worksurfaces or where they connect. When support panels are used where two worksurfaces connect, a mending plate is required.

WHEN ORDERING SPECIFY

- MODEL NUMBER & DESCRIPTION, INCLUDING OPTIONS
- SIZE
- EDGE DETAIL
- FINISH
- OEM MANUFACTURER, IF APPLICABLE

NOTES & OPTIONS

- FRIANT MANUFACTURES SUPPORTS SIZED TO FIT ANY OEM SYSTEM, PLEASE SPECIFY WHICH SYSTEM (SEE PAGE 12)

WORKSURFACE SUPPORTS AND MODESTY PANELS

| MODEL NUMBER | SIZE D x H | WT. | OPTIONS | | |
|--------------|---------------|-----|---------|----------|--------|
| | | | BLACK | LAMINATE | VENEER |

CORNER LEG - L SHAPE

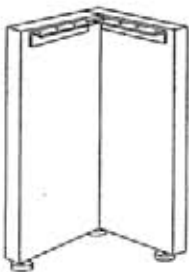

| | | | | | |
|----------|-----------------------|----|-----|-----|-----|
| LSP 1229 | 12 x 27 $\frac{3}{4}$ | 12 | 145 | 195 | 300 |
| LSP 1529 | 15 x 27 $\frac{3}{4}$ | 15 | 155 | 200 | 325 |
| LSP 2029 | 20 x 27 $\frac{3}{4}$ | 19 | 165 | 250 | 355 |

These supports are used to create a freestanding unit.
Use at back corner of a corner worksurface.

MODESTY PANEL



| | | | | | |
|------------|------------------------|-----|-----|-----|------|
| FMSP-3629 | 36 x 27 $\frac{3}{4}$ | 35 | 145 | 165 | 275 |
| FMSP-4829 | 48 x 27 $\frac{3}{4}$ | 47 | 175 | 205 | 425 |
| FMSP-6029 | 60 x 27 $\frac{3}{4}$ | 59 | 220 | 255 | 480 |
| FMSP-7229 | 72 x 27 $\frac{3}{4}$ | 70 | 275 | 315 | 600 |
| FMSP-9629 | 96 x 27 $\frac{3}{4}$ | 94 | 350 | 400 | 850 |
| FMSP-12029 | 120 x 27 $\frac{3}{4}$ | 117 | 420 | 483 | 1015 |

Half height or three-quarter height modesty panels available - call factory for pricing and specifications.

COLUMN BASE



| | | | BLACK | CHROME | OTHER POWDERCOAT |
|------|---------------------------|----|-------|--------|---------------------|
| ME-3 | 3" Dia x 27 $\frac{3}{4}$ | 6 | 120 | 130 | * |
| ME-4 | 4" Dia x 27 $\frac{3}{4}$ | 9 | 160 | 170 | * |
| ME-6 | 6" Dia x 27 $\frac{3}{4}$ | 13 | 275 | 285 | * |

* Call factory for pricing.

WHEN ORDERING SPECIFY

- MODEL NUMBER & DESCRIPTION, INCLUDING OPTIONS
- SIZE
- EDGE DETAIL
- FINISH
- OEM MANUFACTURER, IF APPLICABLE

NOTES & OPTIONS

- CABLE CUT-OUT - SPECIFY LOCATION AND ADD \$25 LIST
- FRIANT MANUFACTURES SUPPORTS SIZED TO FIT ANY OEM SYSTEM, PLEASE SPECIFY WHICH SYSTEM (SEE PAGE 12)

OPTIONAL ACCESSORIES

| MODEL NUMBER | SIZE W x D x H | WT. | OPTIONS | | |
|--------------|-------------------|-----|---------|----------|--------|
| | | | BLACK | LAMINATE | VENEER |
| PD | 22 x 16 | 20 | 135 | 150 | 210 |

PENCIL DRAWER



WIRE MANAGER



| MODEL NUMBER | SIZE W x D x H | WT. | OPTIONS | | |
|--------------|-------------------|-----|---------|----------|--------|
| | | | BLACK | LAMINATE | VENEER |
| WM-2-36 | 36 x 1 x 2 | | 40 | | |
| WM-2-48 | 48 x 1 x 2 | | 55 | | |
| WM-2-60 | 60 x 1 x 2 | | 65 | | |
| WM-2-72 | 72 x 1 x 2 | | 80 | | |

Mounts at back of, or underneath, worksurface.

KEYBOARD PLATFORMS W/ ARTICULATING ARM



Shown w/ Wrist Rest

| MODEL NUMBER | SIZE W x D x H | WT. | MECHANISM | |
|--|-------------------|-----|--------------------|--------------------|
| | | | STANDARD MECHANISM | CLICK-IT MECHANISM |
| Rectangular Platform w/o Wrist Rest | | | | |
| 2111 - R | 21 x 11 | 6 | 235 | N/A |
| Rectangular Platform w/ Wrist Rest | | | | |
| 2111 - RW | 21 x 11 | 6 | 285 | 410 |
| Clipped Corner Platform w/o Wrist Rest | | | | |
| 2811 - C | 28 x 11 | 6 | 235 | 410 |
| Clipped Corner Platform w/ Wrist Rest | | | | |
| 2811 - CW | 28 x 11 | 6 | 285 | 410 |



Shown w/ Wrist Rest

Add C-1 to model number for Click-It mechanism.

WHEN ORDERING SPECIFY

- MODEL NUMBER & DESCRIPTION, INCLUDING OPTIONS
- SIZE
- FINISH

NOTES & OPTIONS

- KEYBOARD PLATFORM IS BLACK MELAMINE
- WRIST REST IS 3" DEEP X 3/4" HIGH AND IS FABRIC COVERED
- STANDARD ARTICULATING ARM IS WEBER KNAPP MICRO ARM #14915
- CLICK-IT IS SPRING-ASSISTED AND REQUIRES NO KNOBS OR LEVERS - SEE PAGE 13 FOR SPECIFICATIONS

PEDESTALS

| MODEL NUMBER | SIZE D x W x H | WT. | OPTIONS | | | |
|--------------|-------------------|-----|-----------------------------|--------------------------------|------------------------------|----------------------------|
| | | | BLACK UNFINISHED BACK | LAMINATE UNFINISHED BACK | LAMINATE FINISHED BACK | VENEER FINISHED BACK |

BOX, BOX, FILE



| | | | | | | |
|-----|--------------|----|-----|-----|-----|-----|
| BBF | 22 x 16 x 27 | 96 | 275 | 325 | 375 | 800 |
|-----|--------------|----|-----|-----|-----|-----|

Standard with lock.

FILE, FILE



| | | | | | | |
|----|--------------|----|-----|-----|-----|-----|
| FF | 22 x 16 x 27 | 96 | 275 | 325 | 375 | 800 |
|----|--------------|----|-----|-----|-----|-----|

Standard with lock.

HINGED DOOR



| | | | | | | |
|----|--------------|----|-----|-----|-----|-----|
| HD | 22 x 16 x 27 | 95 | 275 | 390 | 450 | 700 |
|----|--------------|----|-----|-----|-----|-----|

Specify hinges at left or right. No lock.
For lock - add \$60 list and specify.

LATERAL FILE

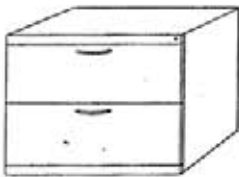

| | | | | | | |
|---------|--------------|-----|-----|-----|-----|------|
| LF - 30 | 22 x 30 x 27 | 180 | 500 | 620 | 700 | 1000 |
| LF - 36 | 22 x 36 x 27 | 210 | 500 | 620 | 700 | 1000 |

Standard with lock.

WHEN ORDERING SPECIFY

- MODEL NUMBER & DESCRIPTION, INCLUDING OPTIONS
- SIZE
- FINISH

NOTES & OPTIONS

- FOR MOBILE PEDESTAL SPECIFY AND ADD \$60 PER PEDESTAL
- STANDARD WITH FRIANT BLACK HANDLES
- STANDARD WITH UNFINISHED TOP
- FOR FREESTANDING UNITS ADD WORKSURFACE, SEE PAGE 16
- KEY LOCKS/ CORES - Casegoods locking storage uses the LAM3 series locks. LAM3 locks are available. They are sold separately through the Willow catalog.
- Please see Willow Pricebook for part numbers and pricing.

OVERHEAD STORAGE

| MODEL NUMBER | SIZE D x W x H | WT. | OPTIONS | | |
|-------------------|-------------------|-----|---------|----------|--------|
| | | | BLACK | LAMINATE | VENEER |
| OPEN SHELF | | | | | |
| WMOS 1536 | 15 x 36 x 18 | 66 | 400 | 500 | 645 |
| WMOS 1548 | 15 x 48 x 18 | 78 | 475 | 570 | 675 |
| WMOS 1560 | 15 x 60 x 18 | 90 | 525 | 620 | 775 |
| WMOS 1572 | 15 x 72 x 18 | 102 | 625 | 700 | 950 |
| WMOS 1596 | 15 x 96 x 18 | 125 | 745 | 870 | 1100 |

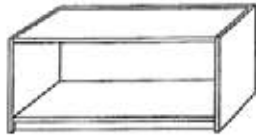

SINGLE HEIGHT FLIPPER OR HINGED DOOR CABINET

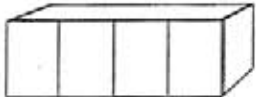
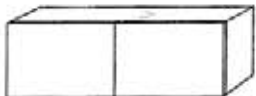

| | | | | | |
|-----------|--------------|-----|-----|------|------|
| WMFD 1536 | 15 x 36 x 18 | 100 | 600 | 675 | 715 |
| WMFD 1548 | 15 x 48 x 18 | 125 | 650 | 750 | 850 |
| WMFD 1560 | 15 x 60 x 18 | 145 | 695 | 825 | 975 |
| WMFD 1572 | 15 x 72 x 18 | 180 | 800 | 910 | 1050 |
| WMFD 1596 | 15 x 96 x 18 | 220 | 900 | 1050 | 1350 |

Standard flipper door flips over top. For hinged doors specify and change F to H in model number.

DOUBLE HIGH HINGED DOOR CABINET

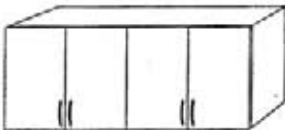

| | | | | | |
|----------------|--------------|-----|-----|------|------|
| WMHD 1536 - 30 | 15 x 36 x 30 | 185 | 685 | 760 | 1072 |
| WMHD 1548 - 30 | 15 x 48 x 30 | 230 | 750 | 840 | 1125 |
| WMHD 1560 - 30 | 15 x 60 x 30 | 265 | 865 | 965 | 1375 |
| WMHD 1572 - 30 | 15 x 72 x 30 | 330 | 980 | 1075 | 1525 |

TASK LIGHT



| | | | PUTTY |
|---------------------------|--------|----|-------|
| TL 24 (Fits 30-36" shelf) | 24.20" | 7 | 135 |
| TL 36 (Fits 42-48" shelf) | 36.20" | 9 | 145 |
| TL 48 (Fits 60" shelf) | 48.20" | 11 | 155 |
| TL 60 (Fits 72" shelf) | 60" | 13 | 175 |

WHEN ORDERING SPECIFY

- MODEL NUMBER & DESCRIPTION, INCLUDING OPTIONS
- SIZE
- FINISH

NOTES & OPTIONS

- WALL MOUNT CLEATS INCLUDED, CALL FOR PANEL MOUNT CLEAT INFORMATION AND PRICING
- TASK LIGHT STANDARD WITH 9' CORD ON RIGHT

- **KEY LOCKS/ CORES** - Caseloads locking storage uses the LAM3 series locks. LAM3 locks are available. They are sold separately through the Willow catalog.
- Please see Willow Pricebook for part numbers and pricing.

FABRIC TACKBOARDS

| MODEL NUMBER | SIZE H x W | WT. | OPTIONS |
|--------------|---------------|-----|---------|
| | | | FABRIC |

SQUARE EDGE TACKBOARD



Square Edge

| | | | |
|---------|---------|----|-----|
| TB __36 | 18 x 36 | 9 | 165 |
| TB __48 | 18 x 48 | 12 | 175 |
| TB __60 | 18 x 60 | 15 | 185 |
| TB __72 | 18 x 72 | 18 | 240 |
| TB __96 | 18 x 96 | 24 | 280 |

Heights of 18" - 24" are same price. Please specify height and fill in model number, i.e., TB 1836.

| | | | |
|---------|---------|----|-----|
| TB __36 | 30 x 36 | 15 | 185 |
| TB __48 | 30 x 48 | 20 | 210 |
| TB __60 | 30 x 60 | 25 | 265 |
| TB __72 | 30 x 72 | 30 | 300 |
| TB __96 | 30 x 96 | 40 | 425 |

Heights of 30" - 36" are same price. Please specify and fill in model number, i.e. TB 3036.

| | | | |
|---------|---------|----|-----|
| TB 4836 | 48 x 36 | 18 | 200 |
| TB 4848 | 48 x 48 | 24 | 265 |
| TB 4860 | 48 x 60 | 30 | 300 |
| TB 4872 | 48 x 72 | 36 | 357 |
| TB 4896 | 48 x 96 | 48 | 465 |

WHEN ORDERING SPECIFY

- MODEL NUMBER & DESCRIPTION, INCLUDING OPTIONS
- SIZE
- FABRIC

NOTES & OPTIONS

- SPECIFY SQUARE EDGE OR RADIUS EDGE
- GUILFORD FR701 FABRIC IS STANDARD
- TACKBOARDS ARE 1" THICK, WITH WALL CLEAT AND TASKLIGHT CORD CUTOUT INCLUDED
- INTERMEDIATE SIZES - PRICE AT NEXT LARGEST SIZE, SPECIFY AND CHANGE MODEL NUMBER





CASEGOODS

TABLE DESKS

| MODEL NUMBER | SIZE D x W | WT. | EDGE DETAILS | | | |
|------------------------|---------------|-----|--------------|---------|---------|---------|
| | | | GROUP 1 | GROUP 2 | GROUP 3 | GROUP 4 |
| PANEL END TABLE | | | | | | |
| PET 2024 | 20 x 24 | 57 | 360 | 410 | 600 | 725 |
| PET 2030 | 20 x 30 | 64 | 400 | 460 | 650 | 775 |
| PET 2036 | 20 x 36 | 71 | 420 | 485 | 685 | 800 |
| PET 2048 | 20 x 48 | 85 | 460 | 529 | 742 | 825 |
| PET 2060 | 20 x 60 | 100 | 500 | 575 | 810 | 900 |
| PET 2072 | 20 x 72 | 114 | 545 | 626 | 850 | 945 |
| PET 2430 | 24 x 30 | 85 | 400 | 460 | 650 | 775 |
| PET 2436 | 24 x 36 | 93 | 420 | 483 | 685 | 800 |
| PET 2448 | 24 x 48 | 109 | 460 | 529 | 742 | 825 |
| PET 2460 | 24 x 60 | 125 | 500 | 575 | 810 | 900 |
| PET 2472 | 24 x 72 | 141 | 545 | 626 | 850 | 945 |
| PET 3036 | 30 x 36 | 111 | 450 | 520 | 685 | 800 |
| PET 3048 | 30 x 48 | 129 | 520 | 600 | 756 | 840 |
| PET 3060 | 30 x 60 | 147 | 555 | 638 | 780 | 865 |
| PET 3072 | 30 x 72 | 165 | 660 | 750 | 883 | 950 |
| PET 3660 | 36 x 60 | 194 | 675 | 770 | 930 | 1000 |
| PET 3672 | 36 x 72 | 216 | 740 | 851 | 1064 | 1145 |
| PET 3696 | 36 x 96 | 225 | 775 | 900 | 1150 | 1200 |

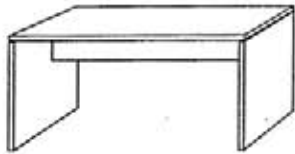

WHEN ORDERING SPECIFY

- MODEL NUMBER & DESCRIPTION, INCLUDING OPTIONS
- SIZE
- EDGE DETAIL
- FINISH

NOTES & OPTIONS

- STANDARD 10" HIGH MODESTY RECESSED 6" FROM BACK EDGE
- OPTIONAL CENTERED 10" MODESTY AVAILABLE
- INTERMEDIATE SIZES - PRICE AT NEXT LARGEST SIZE, SPECIFY AND CHANGE MODEL NUMBER

DESK & CREDENZA SHELLS

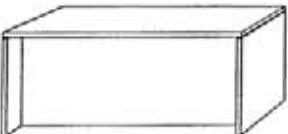
| | MODEL NUMBER | SIZE D x W | WT. | EDGE DETAILS | | | |
|---|--------------|---------------|-----|--------------|---------|---------|---------|
| | | | | GROUP 1 | GROUP 2 | GROUP 3 | GROUP 4 |
| DESK / CREDENZA SHELL | | | | | | | |
|  View As Seated | CS 2048 | 20 x 48 | 93 | 460 | 529 | 742 | 825 |
| | CS 2060 | 20 x 60 | 113 | 500 | 575 | 810 | 900 |
| | CS 2072 | 20 x 72 | 133 | 545 | 626 | 850 | 945 |
|  Front View | DS 2448 | 24 x 48 | 131 | 460 | 529 | 742 | 825 |
| | DS 2460 | 24 x 60 | 153 | 500 | 575 | 810 | 900 |
| | DS 2472 | 24 x 72 | 175 | 545 | 626 | 850 | 945 |
| | DS 3048 | 30 x 48 | 174 | 520 | 600 | 756 | 840 |
| | DS 3060 | 30 x 60 | 198 | 555 | 638 | 780 | 865 |
| | DS 3072 | 30 x 72 | 222 | 660 | 750 | 883 | 950 |
| | DS 3660 | 36 x 60 | 218 | 675 | 770 | 930 | 1000 |
| | DS 3672 | 36 x 72 | 244 | 740 | 851 | 1064 | 1145 |
| | DS 3696 | 36 x 96 | 250 | 760 | 875 | 1125 | 1200 |

WHEN ORDERING SPECIFY

- MODEL NUMBER & DESCRIPTION, INCLUDING OPTIONS
- SIZE
- EDGE DETAIL
- FINISH

NOTES & OPTIONS

- INTERMEDIATE SIZES - PRICE AT NEXT LARGEST SIZE, SPECIFY AND CHANGE MODEL NUMBER
- ¾ MODESTY IS STANDARD, SPECIFY FULL MODESTY IF NEEDED

DESKS

| MODEL NUMBER | SIZE D x W | WT. | EDGE DETAILS | | | |
|-----------------------------|---------------|-----|--------------|---------|---------|---------|
| | | | GROUP 1 | GROUP 2 | GROUP 3 | GROUP 4 |
| SINGLE PEDESTAL DESK | | | | | | |
| SP 2460 | 24 x 60 | 240 | 810 | 875 | 1110 | 1275 |
| SP 2472 | 24 x 72 | 265 | 880 | 950 | 1150 | 1350 |
| SP 3060 | 30 x 60 | 265 | 900 | 975 | 1200 | 1310 |
| SP 3072 | 30 x 72 | 290 | 975 | 1050 | 1265 | 1385 |
| SP 3672 | 36 x 72 | 325 | 1060 | 1150 | 1400 | 1575 |

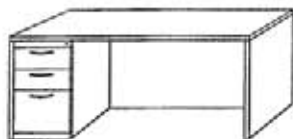

Specify left or right pedestal.

DOUBLE PEDESTAL DESK

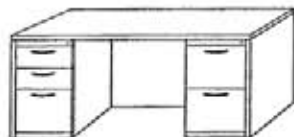

| | | | | | | |
|---------|---------|-----|------|------|------|------|
| DP 2460 | 24 x 60 | 320 | 1150 | 1285 | 1660 | 1850 |
| DP 2472 | 24 x 72 | 340 | 1230 | 1325 | 1760 | 1965 |
| DP 3060 | 30 x 60 | 350 | 1225 | 1320 | 1690 | 1900 |
| DP 3072 | 30 x 72 | 370 | 1300 | 1400 | 1750 | 1975 |
| DP 3672 | 36 x 72 | 400 | 1395 | 1500 | 1900 | 2000 |

WHEN ORDERING SPECIFY

- MODEL NUMBER & DESCRIPTION, INCLUDING OPTIONS
- SIZE
- EDGE DETAIL
- FINISH

NOTES & OPTIONS

- INTERMEDIATE SIZES - PRICE AT NEXT LARGEST SIZE, SPECIFY AND CHANGE MODEL NUMBER
- STANDARD WITH LOCKS
- **KEY LOCKS/ CORES** - Casegoods locking storage uses the LAM3 series locks. LAM3 locks are available. They are sold separately through the Willow catalog.
- Please see Willow Pricebook for part numbers and pricing.

RETURNS

| MODEL NUMBER | SIZE D x W | WT. | EDGE DETAILS | | | |
|--------------|---------------|-----|--------------|---------|---------|---------|
| | | | GROUP 1 | GROUP 2 | GROUP 3 | GROUP 4 |

RETURN SHELL

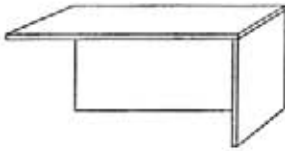

| | | | | | | |
|---------|---------|-----|-----|-----|-----|-----|
| RS 2436 | 24 x 36 | 91 | 395 | 425 | 600 | 695 |
| RS 2448 | 24 x 48 | 113 | 410 | 460 | 650 | 750 |
| RS 2460 | 24 x 60 | 135 | 460 | 495 | 700 | 795 |
| RS 2472 | 24 x 72 | 157 | 525 | 565 | 785 | 850 |
| RS 3036 | 30 x 36 | 103 | 415 | 450 | 660 | 720 |
| RS 3048 | 30 x 48 | 127 | 450 | 485 | 700 | 775 |
| RS 3060 | 30 x 60 | 151 | 500 | 540 | 760 | 840 |
| RS 3072 | 30 x 72 | 175 | 550 | 600 | 800 | 895 |

20" deep return available - specify & change model number.
Specify left or right return.

RETURN W/ PEDESTAL

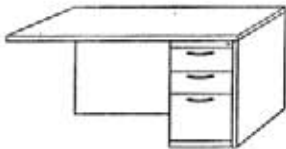

| | | | | | | |
|--------|---------|-----|-----|-----|------|------|
| R 2436 | 24 x 36 | 177 | 730 | 795 | 995 | 1100 |
| R 2448 | 24 x 48 | 199 | 780 | 840 | 1045 | 1165 |
| R 2460 | 24 x 60 | 221 | 800 | 860 | 1100 | 1240 |

Specify left or right return.

WHEN ORDERING SPECIFY

- MODEL NUMBER & DESCRIPTION, INCLUDING OPTIONS
- SIZE
- EDGE DETAIL
- FINISH

NOTES & OPTIONS

- INTERMEDIATE SIZES - PRICE AT NEXT LARGEST SIZE, SPECIFY AND CHANGE MODEL NUMBER

- STANDARD WITH LOCKS

- **KEY LOCKS/ CORES** - Casegoods locking storage uses the LAM3 series locks. LAM3 locks are available. They are sold separately through the Willow catalog.
- Please see Willow Pricebook for part numbers and pricing.

BRIDGE & EXTENDED CORNER DESK

| MODEL NUMBER | SIZE D x W | WT. | EDGE DETAILS | | | |
|--------------------|---------------|-----|--------------|---------|---------|---------|
| | | | GROUP 1 | GROUP 2 | GROUP 3 | GROUP 4 |
| OPEN BRIDGE | | | | | | |
| BR 2036 | 20 x 36 | 30 | 290 | 360 | 500 | 650 |
| BR 2048 | 20 x 48 | 40 | 360 | 410 | 645 | 740 |
| BR 2060 | 20 x 60 | 50 | 390 | 460 | 675 | 800 |
| BR 2436 | 24 x 36 | 40 | 325 | 395 | 550 | 675 |
| BR 2448 | 24 x 48 | 50 | 380 | 440 | 680 | 750 |
| BR 2460 | 24 x 60 | 60 | 420 | 485 | 750 | 835 |
| BR 3036 | 30 x 36 | 45 | 360 | 435 | 600 | 725 |
| BR 3048 | 30 x 48 | 55 | 420 | 490 | 725 | 800 |
| BR 3060 | 30 x 60 | 65 | 455 | 520 | 750 | 850 |

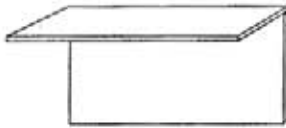

For optional modesty support panel see page 34.

EXTENDED CORNER DESK

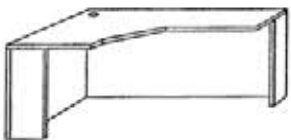
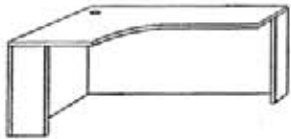

| | | | | | | |
|----------|---------|-----|------|------|------|------|
| ECD 3660 | 36 x 60 | 220 | 895 | 990 | 1615 | 1900 |
| ECD 3672 | 36 x 72 | 245 | 925 | 1025 | 1660 | 1950 |
| ECD 3684 | 36 x 84 | 255 | 975 | 1085 | 1700 | 2000 |
| ECD 3696 | 36 x 96 | 275 | 1055 | 1175 | 1765 | 2075 |
| ECD 4860 | 48 x 60 | 280 | 975 | 1085 | 1660 | 1950 |
| ECD 4872 | 48 x 72 | 285 | 1035 | 1148 | 1700 | 2000 |
| ECD 4884 | 48 x 84 | 295 | 1075 | 1195 | 1765 | 2050 |
| ECD 4896 | 48 x 96 | 300 | 1125 | 1250 | 1800 | 2100 |

Specify curved corner or straight corner.
Add \$80 for Keyboard Cutout.

WHEN ORDERING SPECIFY

- MODEL NUMBER & DESCRIPTION, INCLUDING OPTIONS
- SIZE
- EDGE DETAIL
- FINISH

NOTES & OPTIONS

- INTERMEDIATE SIZES - PRICE AT NEXT LARGEST SIZE, SPECIFY AND CHANGE MODEL NUMBER
- EXTENDED CORNER DESKS INCLUDE GROMMET

CORNER SHELL

EDGE DETAILS

| MODEL NUMBER | SIZE D x W | WT. | EDGE DETAILS | | | |
|--------------|---------------|-----|--------------|---------|---------|---------|
| | | | GROUP 1 | GROUP 2 | GROUP 3 | GROUP 4 |

ANGLED CORNER SHELL

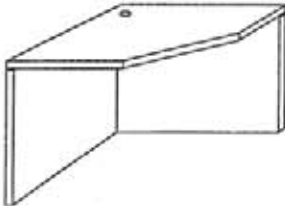

| | | | | | | |
|----------|---------|-----|-----|-----|------|------|
| ACS 3636 | 36 x 36 | 116 | 575 | 610 | 980 | 1150 |
| ACS 4242 | 42 x 42 | 141 | 625 | 700 | 1015 | 1225 |
| ACS 4848 | 48 x 48 | 167 | 660 | 720 | 1040 | 1250 |

Dimensions of sides that connect with other units need to be specified. Standard sizes are 20", 24", and 30". Please specify both the left side dimension and the right side dimension.

Add \$80 List for Keyboard Cutout

CURVED CORNER SHELL

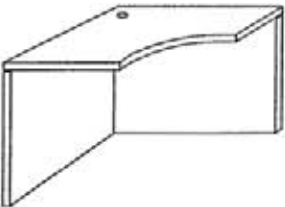

| | | | | | | |
|----------|---------|-----|-----|-----|------|------|
| CCS 3636 | 36 x 36 | 119 | 595 | 630 | 1120 | 1275 |
| CCS 4242 | 42 x 42 | 145 | 645 | 725 | 1175 | 1350 |
| CCS 4848 | 48 x 48 | 172 | 680 | 750 | 1195 | 1375 |

Dimensions of sides that connect with other units need to be specified. Standard sizes are 20", 24", and 30". Please specify both the left side dimension and the right side dimension.

P-LEG CORNER SHELL

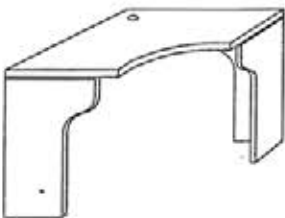

| | | | | | | |
|----------|---------|-----|-----|-----|------|------|
| PCS 3636 | 36 x 36 | 100 | 535 | 570 | 875 | 1000 |
| PCS 4242 | 42 x 42 | 130 | 580 | 635 | 900 | 1100 |
| PCS 4848 | 48 x 48 | 145 | 630 | 685 | 1000 | 1200 |

Dimensions of sides that connect with other units need to be specified. Standard sizes are 20", 24", and 30". Please specify both the left side dimension and the right side dimension.

WHEN ORDERING SPECIFY

- MODEL NUMBER & DESCRIPTION, INCLUDING OPTIONS
- SIZE
- EDGE DETAIL
- FINISH

NOTES & OPTIONS

- INTERMEDIATE SIZES - PRICE AT NEXT LARGEST SIZE, SPECIFY AND CHANGE MODEL NUMBER
- INCLUDES CORNER GROMMET

PENINSULA DESKS

| MODEL NUMBER | SIZE D x W | WT. | EDGE DETAILS | | | |
|---------------------------------|---------------|-----|--------------|---------|---------|---------|
| | | | GROUP 1 | GROUP 2 | GROUP 3 | GROUP 4 |
| D-SHAPE - OPEN W/ COLUMN | | | | | | |
| DD 2448 | 24 x 48 | 68 | 675 | 730 | 1150 | 1400 |
| DD 2460 | 24 x 60 | 78 | 695 | 755 | 1250 | 1450 |
| DD 2472 | 24 x 72 | 88 | 725 | 785 | 1285 | 1500 |
| DD 3060 | 30 x 60 | 95 | 740 | 795 | 1285 | 1500 |
| DD 3072 | 30 x 72 | 107 | 795 | 855 | 1340 | 1565 |
| DD 3672 | 36 x 72 | 118 | 850 | 920 | 1395 | 1620 |
| DD 3696 | 36 x 96 | 125 | 900 | 950 | 1425 | 1700 |

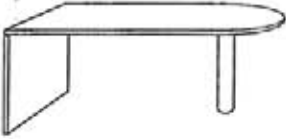

D-SHAPE - W/ FULL MODESTY PANEL W/ COLUMN

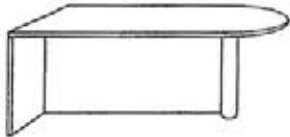

| | | | | | | |
|----------|---------|-----|------|------|------|------|
| DDM 2448 | 24 x 48 | 118 | 850 | 905 | 1325 | 1825 |
| DDM 2460 | 24 x 60 | 138 | 915 | 975 | 1470 | 1900 |
| DDM 2472 | 24 x 72 | 161 | 1000 | 1060 | 1560 | 2050 |
| DDM 3060 | 30 x 60 | 156 | 915 | 975 | 1485 | 2050 |
| DDM 3072 | 30 x 72 | 180 | 1070 | 1295 | 1615 | 2110 |
| DDM 3672 | 36 x 72 | 191 | 1125 | 1195 | 1670 | 2170 |
| DDM 3696 | 36 x 96 | 205 | 1250 | 1345 | 1850 | 2295 |

WHEN ORDERING SPECIFY

- MODEL NUMBER & DESCRIPTION, INCLUDING OPTIONS
- SIZE
- EDGE DETAIL
- FINISH

NOTES & OPTIONS

- INTERMEDIATE SIZES - PRICE AT NEXT LARGEST SIZE, SPECIFY AND CHANGE MODEL NUMBER

DESK MOUNT HUTCH & BOOKCASES

| MODEL NUMBER | SIZE D x W x H | WT. | OPTIONS | |
|--------------|-------------------|-----|----------|-------------------|
| | | | LAMINATE | GROUP 4 VENEER |

FLIPPER OR HINGED DOOR DESK MOUNT HUTCH

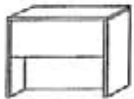

| | | | | |
|---------------|--------------|-----|------|------|
| OSC 1536 - 42 | 15 x 36 x 42 | 141 | 925 | 1300 |
| OSC 1548 - 42 | 15 x 48 x 42 | 175 | 985 | 1350 |
| OSC 1560 - 42 | 15 x 60 x 42 | 212 | 1000 | 1380 |
| OSC 1572 - 42 | 15 x 72 x 42 | 245 | 1100 | 1475 |

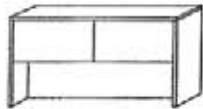

Specify flipper door or hinged door.
For optional top edge detail in groups 2 and 3 add \$70 list per linear foot.
Group 4 top edge detail is included.

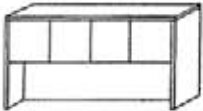

TWO SHELF BOOKCASE

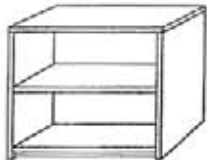

| | | | BLACK | LAMINATE | VENEER |
|------------|--------------|----|-------|----------|--------|
| BC 1230-29 | 12 x 30 x 29 | 62 | 350 | 440 | 810 |
| BC 1236-29 | 12 x 36 x 29 | 70 | 375 | 475 | 845 |
| BC 1242-29 | 12 x 42 x 29 | 78 | 500 | 600 | 900 |
| BC 1248-29 | 12 x 48 x 29 | 86 | 600 | 725 | 950 |

WHEN ORDERING SPECIFY

- MODEL NUMBER & DESCRIPTION, INCLUDING OPTIONS
- SIZE
- EDGE DETAIL
- FINISH

NOTES & OPTIONS

- HUTCH STANDARD WITH UNFINISHED BACK
- FOR LOCKS ADD \$50 AND SPECIFY

- **KEY LOCKS/ CORES** - Caseloads locking storage uses the LAM3 series locks. LAM3 locks are available. They are sold separately through the Willow catalog.
- Please see Willow Pricebook for part numbers and pricing.

BOOKCASES

| MODEL NUMBER | SIZE D x W x H | WT. | OPTIONS | | |
|--------------|-------------------|-----|---------|----------|--------|
| | | | BLACK | LAMINATE | VENEER |

THREE SHELF BOOKCASE

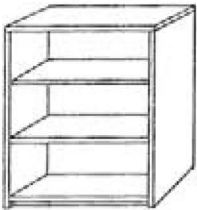

| | | | | | |
|------------|--------------|-----|-----|-----|-----|
| BC 1230-36 | 12 x 30 x 36 | 80 | 475 | 525 | 750 |
| BC 1236-36 | 12 x 36 x 36 | 91 | 495 | 550 | 800 |
| BC 1248-36 | 12 x 48 x 36 | 112 | 700 | 780 | 950 |

FOUR SHELF BOOKCASE

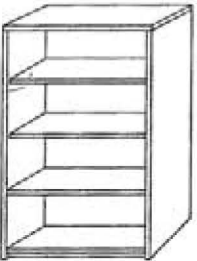

| | | | | | |
|------------|--------------|-----|-----|-----|------|
| BC 1230-48 | 12 x 30 x 48 | 103 | 565 | 625 | 800 |
| BC 1236-48 | 12 x 36 x 48 | 116 | 600 | 675 | 850 |
| BC 1248-48 | 12 x 48 x 48 | 142 | 775 | 875 | 1000 |

FIVE SHELF BOOKCASE

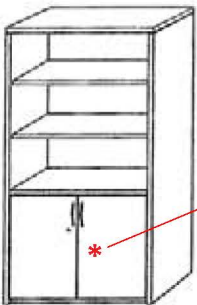

| | | | | | |
|------------|--------------|-----|-----|------|------|
| BC 1230-72 | 12 x 30 x 72 | 136 | 735 | 825 | 1000 |
| BC 1236-72 | 12 x 36 x 72 | 151 | 760 | 895 | 1100 |
| BC 1248-72 | 12 x 48 x 72 | 182 | 925 | 1000 | 1200 |

Hinged door option shown but not included. Refer to pt. 2 below.

WHEN ORDERING SPECIFY

- MODEL NUMBER & DESCRIPTION, INCLUDING OPTIONS
- SIZE
- EDGE DETAIL
- FINISH

NOTES & OPTIONS

- 1 FOUR HIGH BOOKCASE ALSO AVAILABLE 60" HIGH, FIVE HIGH BOOKCASE ALSO AVAILABLE 84" HIGH. CALL FOR PRICING
- 2 FOR LAMINATE DOORS 29" HIGH ADD \$160 LIST PER PAIR
- 3 FOR VENEER DOORS 29" HIGH ADD \$210 LIST PER PAIR

LATERAL FILES

EDGE DETAILS

| MODEL NUMBER | SIZE D x W x H | WT. | EDGE DETAILS | | | |
|--------------|-------------------|-----|--------------|---------|---------|---------|
| | | | GROUP 1 | GROUP 2 | GROUP 3 | GROUP 4 |

CREDENZA LATERAL FILE

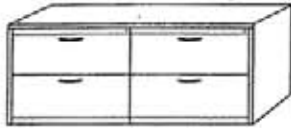

| | | | | | | |
|----------|--------------|-----|------|------|------|------|
| CLF 2060 | 20 x 60 x 29 | 300 | 1650 | 1725 | 1965 | 2300 |
| CLF 2072 | 20 x 72 x 29 | 330 | 1725 | 1800 | 2100 | 2500 |

TWO HIGH LATERAL

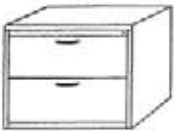

| | | | | | | |
|----------|--------------|-----|-----|-----|------|------|
| LF2 - 30 | 22 x 30 x 29 | 180 | 745 | 800 | 945 | 1300 |
| LF2 - 36 | 22 x 36 x 29 | 210 | 765 | 825 | 985 | 1345 |
| LF2 - 42 | 22 x 42 x 29 | 240 | 820 | 885 | 1140 | 1385 |

THREE HIGH LATERAL



| | | | | | | |
|----------|--------------|-----|------|------|------|------|
| LF3 - 30 | 22 x 30 x 41 | 230 | 950 | 1000 | 1200 | 1400 |
| LF3 - 36 | 22 x 36 x 41 | 270 | 1000 | 1075 | 1225 | 1450 |
| LF3 - 42 | 22 x 42 x 41 | 310 | 1120 | 1200 | 1375 | 1600 |

FOUR HIGH LATERAL



| | | | | | | |
|----------|--------------|-----|------|------|------|------|
| LF4 - 30 | 22 x 30 x 53 | 240 | 1350 | 1410 | 1550 | 1750 |
| LF4 - 36 | 22 x 36 x 53 | 280 | 1375 | 1450 | 1595 | 1800 |
| LF4 - 42 | 22 x 42 x 53 | 320 | 1475 | 1550 | 1720 | 2000 |

WHEN ORDERING SPECIFY

NOTES & OPTIONS

- MODEL NUMBER & DESCRIPTION, INCLUDING OPTIONS
- SIZE
- EDGE DETAIL
- FINISH

CREDENZAS

EDGE DETAILS

| MODEL NUMBER | SIZE D x W x H | WT. | EDGE DETAILS | | | |
|--------------|-------------------|-----|--------------|---------|---------|---------|
| | | | GROUP 1 | GROUP 2 | GROUP 3 | GROUP 4 |

HINGED DOOR CREDENZA



| | | | | | | |
|----------|--------------|-----|------|------|------|------|
| HDC 2236 | 22 x 36 x 29 | 120 | 770 | 825 | 1000 | 1150 |
| HDC 2248 | 22 x 48 x 29 | 205 | 875 | 945 | 1025 | 1185 |
| HDC 2260 | 22 x 60 x 29 | 265 | 975 | 1075 | 1485 | 2100 |
| HDC 2272 | 22 x 72 x 29 | 310 | 1080 | 1150 | 1655 | 2200 |

KNEE SPACE CREDENZA

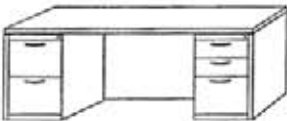

| | | | | | | |
|----------|--------------|-----|------|------|------|------|
| KSC 2260 | 22 x 60 x 29 | 260 | 1150 | 1245 | 1540 | 1775 |
| KSC 2272 | 22 x 72 x 29 | 270 | 1250 | 1345 | 1680 | 1850 |

COMBINATION CREDENZA

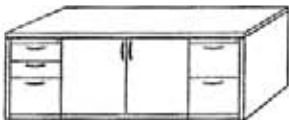

| | | | | | | |
|---------|--------------|-----|------|------|------|------|
| CC 2260 | 22 x 60 x 29 | 330 | 1288 | 1385 | 1700 | 2175 |
| CC 2272 | 22 x 72 x 29 | 350 | 1340 | 1450 | 1830 | 2225 |

WHEN ORDERING SPECIFY

- MODEL NUMBER & DESCRIPTION, INCLUDING OPTIONS
- SIZE
- EDGE DETAIL
- FINISH

NOTES & OPTIONS

- FOR LOCKS - ADD \$60 LIST PER PAIR OF DOORS

- **KEY LOCKS/ CORES** - Caseloads locking storage uses the LAM3 series locks. LAM3 locks are available. They are sold separately through the Willow catalog.
- Please see Willow Pricebook for part numbers and pricing.

STORAGE UNITS - 36" HIGH

EDGE DETAILS

| MODEL NUMBER | SIZE D x W x H | WT. | EDGE DETAILS | | | |
|--------------|-------------------|-----|--------------|---------|---------|---------|
| | | | GROUP 1 | GROUP 2 | GROUP 3 | GROUP 4 |

HINGED DOOR STORAGE CABINET W/ DRAWERS - 36"H

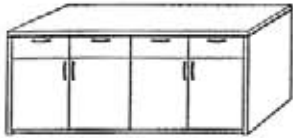

| | | | | | | |
|-----------|--------------|-----|------|------|------|------|
| HDCD 2436 | 24 x 36 x 36 | 120 | 1150 | 1250 | 1675 | 1875 |
| HDCD 2448 | 24 x 48 x 36 | 205 | 1300 | 1390 | 2150 | 2400 |
| HDCD 2460 | 24 x 60 x 36 | 265 | 1650 | 1725 | 2750 | 3000 |
| HDCD 2472 | 24 x 72 x 36 | 310 | 1800 | 1925 | 2950 | 3150 |
| HDCD 2484 | 24 x 84 x 36 | 330 | 2000 | 2275 | 3000 | 3375 |

HINGED DOOR STORAGE CABINET - 36"H

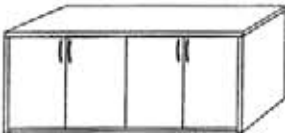

| | | | | | | |
|----------|--------------|-----|------|------|------|------|
| HDC 2436 | 24 x 36 x 36 | 120 | 990 | 1050 | 1200 | 1400 |
| HDC 2448 | 24 x 48 x 36 | 205 | 1110 | 1200 | 1440 | 1600 |
| HDC 2460 | 24 x 60 x 36 | 265 | 1300 | 1470 | 1800 | 2200 |
| HDC 2472 | 24 x 72 x 36 | 310 | 1500 | 1650 | 2175 | 2700 |
| HDC 2484 | 24 x 84 x 36 | 330 | 1700 | 1850 | 2300 | 2850 |

WHEN ORDERING SPECIFY

- MODEL NUMBER & DESCRIPTION, INCLUDING OPTIONS
- SIZE
- EDGE DETAIL
- FINISH

NOTES & OPTIONS

- FOR LOCKS - ADD \$60 LIST PER PAIR OF DOORS

- **KEY LOCKS/ CORES** - Casegoods locking storage uses the LAM3 series locks. LAM3 locks are available. They are sold separately through the Willow catalog.
- Please see Willow Pricebook for part numbers and pricing.

STORAGE UNITS

EDGE DETAILS

| MODEL NUMBER | SIZE D x W x H | WT. | EDGE DETAILS | | | |
|--------------|-------------------|-----|--------------|---------|---------|---------|
| | | | GROUP 1 | GROUP 2 | GROUP 3 | GROUP 4 |

HINGED DOOR/2 DWR LATERAL CABINET

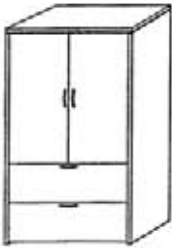

| | | | | | | |
|---------------|--------------|-----|------|------|------|------|
| HDLF 2236 - 2 | 22 x 36 x 72 | 390 | 1650 | 1750 | 1800 | 2100 |
| HDLF 2242 - 2 | 22 x 42 x 72 | 415 | 1700 | 1800 | 1945 | 2300 |

Includes 2 adjustable shelves.
Optional: Hinged door over hinged door cabinet.

HINGED DOOR/3 DWR LATERAL CABINET

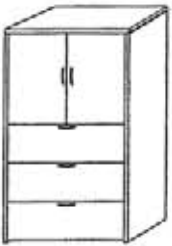

| | | | | | | |
|-------------|--------------|-----|------|------|------|------|
| HDLF 2236-3 | 22 x 36 x 72 | 390 | 1800 | 1900 | 2000 | 2375 |
| HDLF 2242-3 | 22 x 42 x 72 | 415 | 1850 | 2000 | 2225 | 2600 |

WARDROBE CABINET

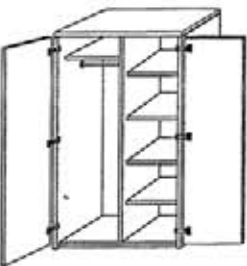

| | | | | | | |
|---------|--------------|-----|------|------|------|------|
| WC 2236 | 22 x 36 x 72 | 310 | 1500 | 1675 | 1850 | 2200 |
|---------|--------------|-----|------|------|------|------|

WHEN ORDERING SPECIFY

- MODEL NUMBER & DESCRIPTION, INCLUDING OPTIONS
- SIZE
- EDGE DETAIL
- FINISH

NOTES & OPTIONS

- FOR LOCKS - ADD \$60 LIST PER PAIR OF DOORS
- KEY LOCKS/ CORES - Casegoods locking storage uses the LAM3 series locks. LAM3 locks are available. They are sold separately through the Willow catalog.
- Please see Willow Pricebook for part numbers and pricing.

VIDEO CABINETS

EDGE DETAILS

| MODEL NUMBER | SIZE D x W x H | WT. | EDGE DETAILS | | | |
|--------------|-------------------|-----|--------------|---------|---------|---------|
| | | | GROUP 1 | GROUP 2 | GROUP 3 | GROUP 4 |

A.V. STAND

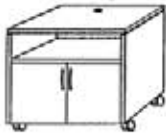

| | | | | | | |
|---------------|--------------|-----|------|------|------|------|
| AVS 2230 - 36 | 22 x 30 x 36 | 260 | 950 | 1050 | 1175 | 1300 |
| AVS 2236 - 38 | 22 x 36 x 36 | 275 | 1000 | 1150 | 1265 | 1380 |

A.V. Stand can hold upto 200 lbs.

A.V. CABINET

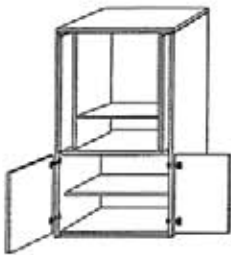

| | | | | | | |
|---------------|--------------|-----|------|------|------|------|
| AVC 2236 - 72 | 22 x 36 x 72 | 360 | 1750 | 1925 | 2800 | 3000 |
| AVC 2242 - 72 | 22 x 42 x 72 | 375 | 2000 | 2200 | 3000 | 3300 |

Upper half pocket doors are standard.

For drawer in upper cabinet - add \$250 and specify.

VCR shelf standard. For pull-out VCR shelf add \$225 list.

Grommets included.

TELEPHONE STAND



| | | | | | | |
|--------------|--------------|-----|-----|-----|-----|-----|
| TS 1824 - 29 | 18 x 24 x 29 | 130 | 500 | 600 | 700 | 850 |
| TS 2230 - 29 | 22 x 30 x 29 | 150 | 600 | 750 | 800 | 900 |

Specify left or right hinged door.

WHEN ORDERING SPECIFY

- MODEL NUMBER & DESCRIPTION, INCLUDING OPTIONS
- SIZE
- EDGE DETAIL
- FINISH

NOTES & OPTIONS

- CUSTOM UNITS AVAILABLE, CALL FOR PRICING

VISUAL BOARDS

| MODEL NUMBER | SIZE H x W | WT. | OPTIONS | |
|--------------|---------------|-----|----------|--------|
| | | | LAMINATE | VENEER |

CABINET UNIT

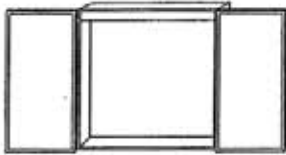

| | | | | |
|----------|---------|-----|------|------|
| VBC 3636 | 36 x 36 | 80 | 1300 | 1450 |
| VBC 3648 | 36 x 48 | 102 | 1375 | 1500 |
| VBC 4848 | 48 x 48 | 128 | 1425 | 1600 |
| VBC 4860 | 48 x 60 | 160 | 1560 | 1700 |
| VBC 4872 | 48 x 72 | 192 | 1630 | 1800 |

For pull down projection screen - add \$175 list.

OPEN WITH TRAY



Radius Edge Frame with Tray

| | SIZE H x W | WT. | LAMINATE | WOOD |
|-----------|---------------|-----|----------|-------|
| | | | NO FRAME | FRAME |
| OVB 3636 | 36 x 36 | 36 | 400 | 625 |
| OVB 3648 | 36 x 48 | 42 | 450 | 650 |
| OVB 4848 | 48 x 48 | 48 | 550 | 700 |
| OVB 4860 | 48 x 60 | 60 | 625 | 750 |
| OVB 4872 | 48 x 72 | 72 | 700 | 800 |
| OVB 4896 | 48 x 96 | 96 | 850 | 1025 |
| OVB 48120 | 48 x 120 | 120 | 1000 | 1200 |

WHEN ORDERING SPECIFY

- MODEL NUMBER & DESCRIPTION, INCLUDING OPTIONS
- SIZE
- EDGE DETAIL
- FINISH

NOTES & OPTIONS

- CUSTOM UNITS AVAILABLE, CALL FOR PRICING
- VISUAL BOARD CABINET HAS TACKABLE FABRIC PANELS ON INSIDE OF DOORS STANDARD



TABLES

TABLES WITH 4" PANEL LEG BASE

EDGE DETAILS

| MODEL NUMBER | SIZE D x W | WT. | EDGE DETAILS | | | | |
|--------------|---------------|-----|--------------|---------|---------|---------|---------|
| | | | GROUP 1 | GROUP 2 | GROUP 3 | GROUP 4 | GROUP 5 |

RECTANGULAR



| | | | | | | | |
|----------|----------|-----|------|------|------|------|------|
| RPB3672 | 36 x 72 | 165 | 775 | 850 | 1200 | 1750 | 1900 |
| RPB3696 | 36 x 96 | 195 | 900 | 975 | 1375 | 1875 | 2300 |
| RPB4296 | 42 x 96 | 210 | 1075 | 1120 | 1525 | 1925 | 2375 |
| RPB4896 | 48 x 96 | 255 | 1125 | 1225 | 1575 | 2250 | 2650 |
| RPB48120 | 48 x 120 | 345 | 1345 | 1475 | 1800 | 2525 | 3150 |
| RPB48144 | 48 x 144 | 380 | 1565 | 1720 | 2300 | 2840 | 3600 |
| RPB48168 | 48 x 168 | 445 | 1900 | 2090 | 2600 | 4100 | 4600 |
| RPB48192 | 48 x 192 | 500 | 2300 | 2535 | 3000 | 4300 | 4870 |

RACETRACK OR CONVEX

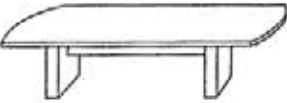

| | | | | | | | |
|-----------|----------|-----|------|------|------|------|------|
| RTPB3672 | 36 x 72 | 165 | 925 | 1100 | 1650 | 1950 | 2300 |
| RTPB3696 | 36 x 96 | 195 | 1050 | 1200 | 1850 | 2200 | 2700 |
| RTPB4296 | 42 x 96 | 210 | 1120 | 1300 | 2000 | 2270 | 2760 |
| RTPB4896 | 48 x 96 | 255 | 1175 | 1400 | 2110 | 2300 | 3075 |
| RTPB48120 | 48 x 120 | 345 | 1500 | 1750 | 2285 | 2800 | 3400 |
| RTPB48144 | 48 x 144 | 380 | 1700 | 1955 | 2600 | 3100 | 3900 |
| RTPB48168 | 48 x 168 | 445 | 2300 | 2650 | 3300 | 4400 | 5000 |
| RTPB48192 | 48 x 192 | 500 | 2525 | 2900 | 3600 | 4750 | 5300 |

BOAT SHAPE



| | | | | | | | |
|-------------|---------------|-----|------|------|------|------|------|
| BSPB243672 | 24 x 36 x 72 | 165 | 925 | 1100 | 1650 | 1950 | 2300 |
| BSPB364296 | 36 x 42 x 96 | 210 | 1120 | 1300 | 2000 | 2270 | 2760 |
| BSPB364896 | 36 x 48 x 96 | 255 | 1175 | 1400 | 2110 | 2300 | 3075 |
| BSPB3648120 | 36 x 48 x 120 | 345 | 1500 | 1750 | 2285 | 2800 | 3400 |
| BSPB3648144 | 36 x 48 x 144 | 380 | 1700 | 1955 | 2600 | 3100 | 3900 |
| BSPB3648168 | 36 x 48 x 168 | 445 | 2300 | 2650 | 3300 | 4400 | 5000 |
| BSPB3654192 | 36 x 54 x 192 | 500 | 2525 | 2900 | 3600 | 4750 | 5300 |

WHEN ORDERING SPECIFY

- MODEL NUMBER & DESCRIPTION, INCLUDING OPTIONS
- SIZE
- EDGE DETAIL
- FINISH

NOTES & OPTIONS

- SPECIFY SHAPE: RECTANGULAR, RACETRACK, CONVEX OR BOAT

TABLE WITH FULL OR HALF CYLINDER BASE

| MODEL NUMBER | SIZE D x W | WT. | EDGE DETAILS | | | | |
|--------------|---------------|-----|--------------|---------|---------|---------|---------|
| | | | GROUP 1 | GROUP 2 | GROUP 3 | GROUP 4 | GROUP 5 |

RECTANGULAR

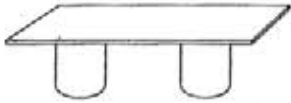

| | | | | | | | |
|----------|----------|-----|------|------|------|------|------|
| CRL3672 | 36 x 72 | 165 | 1250 | 1375 | 1655 | 1800 | 2000 |
| CRL3696 | 36 x 96 | 195 | 1470 | 1600 | 1825 | 1980 | 2200 |
| CRL4296 | 42 x 96 | 210 | 1600 | 1750 | 1945 | 2150 | 2475 |
| CRL4896 | 48 x 96 | 255 | 1700 | 1825 | 2000 | 2225 | 2500 |
| CRL48120 | 48 x 120 | 345 | 1950 | 2100 | 2400 | 2800 | 3200 |
| CRL48144 | 48 x 144 | 380 | 2375 | 2600 | 2725 | 3100 | 3700 |
| CRL48168 | 48 x 168 | 445 | 2800 | 3080 | 3440 | 4000 | 4500 |
| CRL48192 | 48 x 192 | 500 | 3000 | 3275 | 3875 | 4500 | 4800 |

RACETRACK OR CONVEX

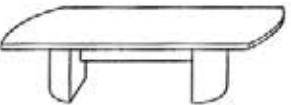
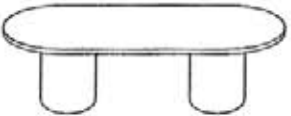

| | | | | | | | |
|----------|----------|-----|------|------|------|------|------|
| CRT3672 | 36 x 72 | 165 | 1425 | 1575 | 1935 | 2150 | 2600 |
| CRT3696 | 36 x 96 | 195 | 1685 | 1830 | 2115 | 2350 | 2900 |
| CRT4296 | 42 x 96 | 210 | 1800 | 1965 | 2320 | 2600 | 3100 |
| CRT4896 | 48 x 96 | 255 | 1900 | 2050 | 2420 | 2700 | 3180 |
| CRT48120 | 48 x 120 | 345 | 2200 | 2375 | 2850 | 3185 | 3525 |
| CRT48144 | 48 x 144 | 380 | 2400 | 2600 | 3230 | 3590 | 4200 |
| CRT48168 | 48 x 168 | 445 | 2950 | 3210 | 3750 | 4175 | 4900 |
| CRT48192 | 48 x 192 | 500 | 3100 | 3420 | 4125 | 4590 | 5400 |

BOAT SHAPE

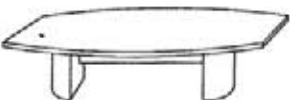
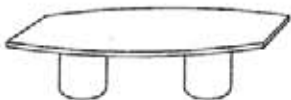

| | | | | | | | |
|------------|---------------|-----|------|------|------|------|------|
| CBS243672 | 24 x 36 x 72 | 165 | 1425 | 1575 | 1935 | 2150 | 2600 |
| CBS364296 | 36 x 42 x 96 | 210 | 1800 | 1965 | 2320 | 2600 | 3100 |
| CBS364896 | 36 x 48 x 96 | 255 | 1900 | 2050 | 2420 | 2700 | 3180 |
| CBS3648120 | 36 x 48 x 120 | 345 | 2200 | 2375 | 2850 | 3185 | 3525 |
| CBS3648144 | 36 x 48 x 144 | 380 | 2400 | 2600 | 3230 | 3590 | 4200 |
| CBS3648168 | 36 x 48 x 168 | 445 | 2950 | 3210 | 3750 | 4175 | 4900 |
| CBS3654192 | 36 x 54 x 192 | 500 | 3100 | 3420 | 4125 | 4590 | 5400 |

WHEN ORDERING SPECIFY

- MODEL NUMBER & DESCRIPTION, INCLUDING OPTIONS
- SIZE
- EDGE DETAIL
- FINISH

NOTES & OPTIONS

- SPECIFY SHAPE: RECTANGULAR, RACETRACK, CONVEX OR BOAT
- SPECIFY FULL OR HALF CYLINDER BASE

TABLES WITH ATLAS T AND TT BASE

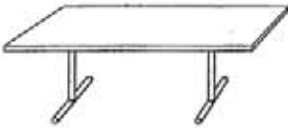
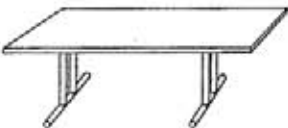
| | MODEL NUMBER | SIZE D x W | WT. | EDGE DETAILS | | | | |
|--|--------------|---------------|------|--------------|---------|---------|---------|---------|
| | | | | GROUP 1 | GROUP 2 | GROUP 3 | GROUP 4 | GROUP 5 |
| RECTANGULAR | | | | | | | | |
|  | RL2436 - 2 | 24 x 36 | 70 | 400 | 485 | 575 | 675 | 700 |
| | RL2448 - 2 | 24 x 48 | 80 | 420 | 500 | 625 | 700 | 850 |
| | RL2460 - 2 | 24 x 60 | 90 | 440 | 528 | 675 | 900 | 975 |
| | RL2472 - 2 | 24 x 72 | 100 | 475 | 560 | 750 | 1050 | 1111 |
| | RL2496 - 2 | 24 x 96 | 120 | 555 | 666 | 900 | 1250 | 1127 |
|  | RL3036 - 2 | 30 x 36 | 74 | 420 | 505 | 645 | 720 | 795 |
| | RL3048 - 2 | 30 x 48 | 84 | 450 | 515 | 675 | 756 | 910 |
| | RL3060 - 2 | 30 x 60 | 94 | 470 | 540 | 750 | 850 | 1000 |
| | RL3072 - 2 | 30 x 72 | 104 | 500 | 600 | 825 | 930 | 1065 |
| | RL3096 - 2 | 30 x 96 | 124 | 640 | 768 | 1025 | 1150 | 1353 |
| | RL3648 - 2 | 36 x 48 | 92 | 500 | 600 | 750 | 900 | 1100 |
| | RL3660 - 2 | 36 x 60 | 120 | 520 | 624 | 850 | 1000 | 1400 |
| | RL3672 - 2 | 36 x 72 | 135 | 575 | 690 | 950 | 1200 | 1700 |
| | RL3696 - 2 | 36 x 96 | 165 | 675 | 810 | 1100 | 1550 | 1875 |
| | RL36120 - 3 | 36 x 120 | 195 | 975 | 1170 | 1400 | 1825 | 2750 |
| RL4872 - 2 | 48 x 72 | 165 | 775 | 925 | 1250 | 1550 | 1825 | |
| RL4896 - 2 | 48 x 96 | 205 | 950 | 1140 | 1460 | 1650 | 2100 | |
| RL48120 - 3 | 48 x 120 | 246 | 1175 | 1410 | 1800 | 2150 | 2750 | |
| RL48144 - 3 | 48 x 144 | 308 | 1400 | 1680 | 2070 | 2500 | 3300 | |
| RL48168 - 4 | 48 x 168 | 348 | 1750 | 2010 | 2500 | 3800 | 4100 | |
| RL48192 - 4 | 48 x 192 | 388 | 2100 | 2400 | 2700 | 4100 | 4500 | |

24" and 30" deep tables come with T base, 36" and 48" deep tables come with TT base.

WHEN ORDERING SPECIFY

- MODEL NUMBER & DESCRIPTION, INCLUDING OPTIONS
- SIZE
- EDGE DETAIL
- FINISH

NOTES & OPTIONS

- FOR STANDARD GROMMET ADD \$25
- BLACK POWDERCOAT BASE STANDARD
- FOR CASTERS: ADD \$15 LIST PER CASTER OR \$25 LIST PER LOCKING CASTER

TABLES WITH ATLAS T OR TT BASE

| MODEL NUMBER | SIZE D x W | WT. | EDGE DETAILS | | | | |
|----------------------------|---------------|-----|--------------|---------|---------|---------|---------|
| | | | GROUP 1 | GROUP 2 | GROUP 3 | GROUP 4 | GROUP 5 |
| RACETRACK OR CONVEX | | | | | | | |
| RT3672 - 2 | 36 x 72 | 135 | 800 | 900 | 1400 | 1600 | 2010 |
| RT3696 - 2 | 36 x 96 | 165 | 875 | 985 | 1575 | 1780 | 2175 |
| RT4296 - 2 | 42 x 96 | 185 | 1100 | 1232 | 1715 | 1975 | 2400 |
| RT4896 - 2 | 48 x 96 | 205 | 1220 | 1366 | 1965 | 2100 | 2600 |
| RT48120 - 3 | 48 x 120 | 246 | 1450 | 1624 | 2075 | 2350 | 3400 |
| RT48144 - 3 | 48 x 144 | 308 | 1650 | 1848 | 2320 | 2800 | 3750 |
| RT48168 - 4 | 48 x 168 | 348 | 2100 | 2350 | 2800 | 3100 | 4270 |
| RT48192 - 4 | 48 x 192 | 388 | 2300 | 2600 | 2975 | 3500 | 4800 |

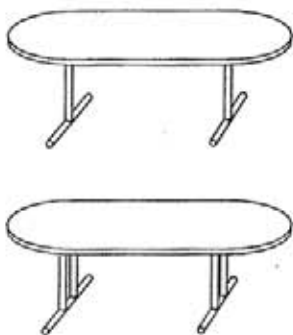

Specify Racetrack or Convex top.

BOAT SHAPE



| | | | | | | | |
|---------------|---------------|-----|------|------|------|------|------|
| BS243672 - 2 | 24 x 36 x 72 | 135 | 800 | 900 | 1400 | 1600 | 2010 |
| BS364296 - 2 | 36 x 42 x 96 | 185 | 1100 | 1232 | 1715 | 1975 | 2400 |
| BS364896 - 2 | 36 x 48 x 96 | 205 | 1220 | 1366 | 1965 | 2100 | 2600 |
| BS3648120 - 3 | 36 x 48 x 120 | 246 | 1450 | 1624 | 2075 | 2350 | 3400 |
| BS3648144 - 3 | 36 x 48 x 144 | 308 | 1650 | 1848 | 2320 | 2800 | 3750 |
| BS3648168 - 4 | 36 x 48 x 168 | 348 | 2100 | 2350 | 2800 | 3100 | 4270 |
| BS3654192 - 4 | 36 x 54 x 192 | 388 | 2300 | 2600 | 2975 | 3500 | 4800 |

36", 42" and 48" deep tables come with TT base.

WHEN ORDERING SPECIFY

- MODEL NUMBER & DESCRIPTION, INCLUDING OPTIONS
- SIZE
- EDGE DETAIL
- FINISH

NOTES & OPTIONS

- FOR STANDARD GROMMET ADD \$25
- BLACK POWDERCOAT BASE STANDARD
- FOR CASTERS: ADD \$15 LIST PER CASTER OR \$25 LIST PER LOCKING CASTER

TABLES WITH ATLAS FOLDING BASE

| MODEL NUMBER | SIZE D x W | WT. | EDGE DETAILS | | | | |
|--------------|---------------|-----|--------------|---------|---------|---------|---------|
| | | | GROUP 1 | GROUP 2 | GROUP 3 | GROUP 4 | GROUP 5 |

RECTANGULAR WITH FOLDING "T" AND FOLDING "TT"



| | | | | | | | |
|-------------|---------|-----|------|------|------|------|-----|
| FRL2460 - 2 | 24 x 60 | 112 | 750 | 850 | 1035 | 1235 | N/A |
| FRL2472 - 2 | 24 x 72 | 118 | 775 | 880 | 1250 | 1500 | N/A |
| FRL3060 - 2 | 30 x 60 | 120 | 825 | 900 | 1250 | 1500 | N/A |
| FRL3072 - 2 | 30 x 72 | 136 | 875 | 925 | 1300 | 1750 | N/A |
| FRL3672 - 2 | 36 x 72 | 157 | 900 | 955 | 1330 | 1965 | N/A |
| FRL3696 - 2 | 36 x 96 | 187 | 1025 | 1075 | 1575 | 2175 | N/A |
| FRL4272 - 2 | 42 x 72 | 172 | 1350 | 1485 | 1830 | 2300 | N/A |
| FRL4296 - 2 | 42 x 96 | 202 | 1550 | 1700 | 2090 | 2500 | N/A |

24" and 30" deep tables come with T base, 36" and 42" deep tables come with TT base.

WHEN ORDERING SPECIFY

- MODEL NUMBER & DESCRIPTION, INCLUDING OPTIONS
- SIZE
- EDGE DETAIL
- FINISH

NOTES & OPTIONS

- FOR CASTERS: ADD \$15 LIST PER CASTER OR \$25 LIST PER LOCKING CASTER

TABLE WITH ATLAS X BASE

| MODEL NUMBER | SIZE D x W | WT. | EDGE DETAILS | | | | |
|--------------|---------------|-----|--------------|---------|---------|---------|---------|
| | | | GROUP 1 | GROUP 2 | GROUP 3 | GROUP 4 | GROUP 5 |
| ROUND | | | | | | | |
| R30 - X | 30 dia | 40 | 375 | 390 | 775 | 925 | 1010 |
| R36 - X | 36 dia | 52 | 400 | 440 | 800 | 950 | 1050 |
| R42 - X | 42 dia | 69 | 550 | 605 | 1000 | 1200 | 1300 |
| R48 - X | 48 dia | 96 | 620 | 682 | 1105 | 1300 | 1365 |
| R54 - X | 54 dia | 104 | 850 | 935 | 1300 | 1485 | 1575 |
| R60 - X | 60 dia | 126 | 900 | 990 | 1400 | 1625 | 1715 |



SQUARE

| | | | | | | | |
|-----------|---------|-----|-----|-----|------|------|------|
| S3030 - X | 30 x 30 | 46 | 350 | 385 | 743 | 875 | 985 |
| S3636 - X | 36 x 36 | 61 | 385 | 425 | 760 | 895 | 1025 |
| S4242 - X | 42 x 42 | 82 | 525 | 577 | 965 | 1125 | 1160 |
| S4848 - X | 48 x 48 | 108 | 625 | 690 | 1160 | 1225 | 1285 |
| S5454 - X | 54 x 54 | 129 | 725 | 797 | 1335 | 1400 | 1545 |
| S6060 - X | 60 x 60 | 153 | 775 | 860 | 1475 | 1550 | 1695 |

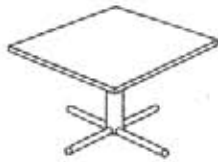



WHEN ORDERING SPECIFY

- MODEL NUMBER & DESCRIPTION, INCLUDING OPTIONS
- SIZE
- EDGE DETAIL
- FINISH

NOTES & OPTIONS

- FOR CASTERS: ADD \$15 LIST PER CASTER OR \$25 LIST PER LOCKING CASTER

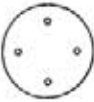
TABLES WITH COLUMN BASE

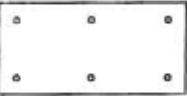
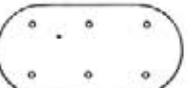
| | MODEL NUMBER | SIZE D x W | WT. | EDGE DETAILS | | | | |
|--|--------------|---------------|-----|--------------|---------|---------|---------|---------|
| | | | | GROUP 1 | GROUP 2 | GROUP 3 | GROUP 4 | GROUP 5 |
| ROUND | | | | | | | | |
|  | R42 | 42 dia | 72 | 775 | 875 | 1075 | 1150 | N/A |
| | R48 | 48 dia | 92 | 775 | 875 | 1075 | 1150 | N/A |
| | R60 | 60 dia | 122 | 935 | 1015 | 1536 | 1575 | N/A |
| SQUARE | | | | | | | | |
|  | S4242 | 42 x 42 | 85 | 735 | 825 | 1000 | 1100 | N/A |
| | S4848 | 48 x 48 | 105 | 735 | 825 | 1000 | 1100 | N/A |
| | S6060 | 60 x 60 | 145 | 915 | 1000 | 1450 | 1500 | N/A |
| HALF ROUND | | | | | | | | |
|  | HR2448 | 24 x 48 | 52 | 545 | 600 | 800 | 975 | N/A |
| | HR3060 | 30 x 60 | 68 | 595 | 650 | 850 | 1000 | N/A |
| | HR3672 | 36 x 72 | 92 | 705 | 785 | 975 | 1200 | N/A |
| RECTANGULAR | | | | | | | | |
|  | RL2448 | 24 x 48 | 82 | 637 | 677 | 757 | 965 | N/A |
| | RL3048 | 30 x 48 | 88 | 657 | 705 | 805 | 990 | N/A |
| | RL3060 | 30 x 60 | 98 | 695 | 745 | 840 | 1075 | N/A |
| | RL3672 | 36 x 72 | 114 | 757 | 820 | 1010 | 1315 | N/A |
| | RL4896 | 48 x 96 | 185 | 1080 | 1130 | 1510 | 1765 | N/A |
| | RL48120 | 48 x 120 | 225 | 1435 | 1500 | 1950 | 2200 | N/A |
| RACETRACK | | | | | | | | |
|  | RT CT3672 | 36 x 72 | 114 | 1000 | 1075 | 1600 | 1795 | N/A |
| | RT CT4896 | 48 x 96 | 185 | 1135 | 1255 | 2100 | 2325 | N/A |
| | RT CT48120 | 48 x 120 | 225 | 1550 | 1675 | 2475 | 2700 | N/A |

WHEN ORDERING SPECIFY

- MODEL NUMBER & DESCRIPTION, INCLUDING OPTIONS
- SIZE
- EDGE DETAIL
- FINISH

NOTES & OPTIONS

- TELECOMMUNICATIONS GROMMET AVAILABLE - CALL FACTORY
- WIRE MANAGEMENT LEG AVAILABLE - CALL FACTORY

OCCASIONAL TABLES

EDGE DETAILS

| MODEL NUMBER | SIZE D x W x H | WT. | EDGE DETAILS | | | | |
|--------------|-------------------|-----|--------------|---------|---------|---------|---------|
| | | | GROUP 1 | GROUP 2 | GROUP 3 | GROUP 4 | GROUP 5 |

CUBE TABLE

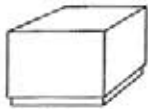

| | | | | | | |
|---------|--------------|-----|-----|-----|-----|-----|
| CT 1818 | 18 x 18 x 24 | 70 | 250 | 375 | 475 | 500 |
| CT 2424 | 24 x 24 x 24 | 100 | 275 | 400 | 600 | 625 |
| CT 3030 | 30 x 30 x 24 | 132 | 325 | 450 | 700 | 750 |

For recessed toe kick - add \$80 list.

CYLINDER TABLE



| | | | | | | |
|--------|-------------|-----|-----|-----|------|------|
| CYT 20 | 20 dia x 22 | 75 | 475 | 600 | 720 | 760 |
| CYT 24 | 24 dia x 22 | 100 | 500 | 625 | 850 | 900 |
| CYT 30 | 30 dia x 22 | 135 | 600 | 725 | 1075 | 1150 |
| CYT 36 | 36 dia x 22 | 170 | 675 | 800 | 1175 | 1275 |

For recessed toe kick - add \$80 list.

PARSONS LEG TABLE



| | | | | | | |
|----------|---------|----|-----|-----|------|------|
| PLT 1836 | 18 x 36 | 55 | 515 | 575 | 875 | 975 |
| PLT 1848 | 18 x 48 | 60 | 575 | 645 | 1000 | 1100 |
| PLT 1860 | 18 x 60 | 67 | 625 | 700 | 1145 | 1270 |
| PLT 2248 | 22 x 48 | 65 | 685 | 765 | 1095 | 1220 |
| PLT 2260 | 22 x 60 | 77 | 720 | 805 | 1215 | 1350 |
| PLT 2272 | 22 x 72 | 89 | 750 | 840 | 1350 | 1500 |

Available 24" high or 29" high, please specify.

WHEN ORDERING SPECIFY

- MODEL NUMBER & DESCRIPTION, INCLUDING OPTIONS
- SIZE
- EDGE DETAIL
- FINISH

NOTES & OPTIONS

RECEPTION STATIONS

BASIC RECEPTION STATION

EDGE DETAILS

| MODEL NUMBER | SIZE D x W | WT. | EDGE DETAILS | | | |
|--------------|---------------|-----|--------------|---------|---------|---------|
| | | | GROUP 1 | GROUP 2 | GROUP 3 | GROUP 4 |

BASIC FRONT DESK



| | | | | | | |
|----------|----------|-----|------|---|---|------|
| BD 3072 | 30 x 72 | 360 | 1865 | * | * | 3500 |
| BD 3096 | 30 x 96 | 425 | 2000 | * | * | 4775 |
| BD 30120 | 30 x 120 | 460 | 2700 | * | * | 5500 |

* Call factory for pricing.

For transaction counter options see page 30.

Includes one BBF locking pedestal per station. Specify front desk or return for pedestal location.

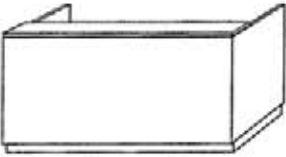

BASIC RETURN W/ TRANSACTION COUNTER

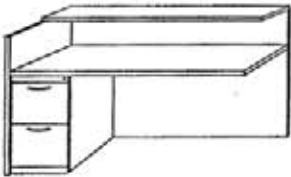

| | | | | | | |
|---------|---------|-----|------|---|---|------|
| BR 2436 | 24 x 36 | 165 | 925 | * | * | 1450 |
| BR 2448 | 24 x 48 | 180 | 1000 | * | * | 1700 |
| BR 2460 | 24 x 60 | 210 | 1100 | * | * | 2000 |
| BR 2472 | 24 x 72 | 225 | 1325 | * | * | 2600 |

| | | | | | | |
|---------|---------|-----|------|---|---|------|
| BR 3036 | 30 x 36 | 185 | 975 | * | * | 1500 |
| BR 3048 | 30 x 48 | 200 | 1025 | * | * | 2000 |
| BR 3060 | 30 x 60 | 230 | 1175 | * | * | 2400 |
| BR 3072 | 30 x 72 | 245 | 1450 | * | * | 2800 |

* Call factory for pricing.

Specify left or right return.

Returns are standard at 29" H.

For transaction counter options see page 30.

Shown with optional FF pedestal. Not included in price unless pedestal is not specified in front desk.

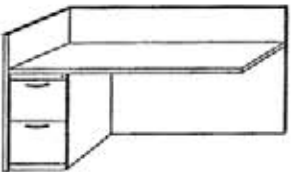

WHEN ORDERING SPECIFY

- MODEL NUMBER & DESCRIPTION, INCLUDING OPTIONS
- SIZE
- EDGE DETAIL
- FINISH
- GROMMET LOCATION

NOTES & OPTIONS

- EACH RECEPTION STATION INCLUDES 1 PEDESTAL WHICH CAN BE SPECIFIED IN FRONT DESK OR, IF SPECIFIED, IN THE RETURN - FOR ADDITIONAL COMPONENTS, SEE PAGE 36
- ONE GROMMET STANDARD
- FOR LAMINATE REVEAL ADD \$300
FOR BRUSHED METAL REVEAL ADD \$500
- ADD \$20 PER FOOT FOR WIRE MANAGER
- FOR TASK LIGHT ADD \$175