

MY-HITE

COLLECTION



TABLE OF CONTENTS

INTRODUCTION

Terms and Conditions	4
Standard Fabrics	7
Pattern Direction	8
Standard Finishes	9

MY-HITE

Grommet Locations	10-15
Power Grommet	16
How to specify 2 piece tops	17
Mobile Pedestals	18
Freestanding Application	19
Workstation Application	20
Beam Application	21

3 STAGE SPECIFIC

Base Application & Electrical Draw	22
Trough Cover Dimension	23
Recommended Top Application	24
Technical Specifications	25

2 STAGE SPECIFIC

Base Application & Electrical Draw	27
Recommended Top Application	28
Technical Specifications	29

BEAM

How to order Beam	67
Worksurface Planning Guide	69
Beam Elevation Height	70
Beam Creep	71
Data Port Plate	72

SPECIFY 3 STAGE BASE

Straight T-Leg	32
Straight C-Leg	33
Corner T-Leg	34
Corner C-Leg	35
Corner T-Leg Post	36
Corner C-Leg Post	37

SPECIFY 2 STAGE BASE

Straight T-Leg	39
Corner T-Leg	40

WORKSURFACES FOR FREESTANDING APPLICATION

Rectangular	42
Corner	43
90° Extended Curved Corner	44
Rectangular Extension	47
D-Shaped	49
Wedge	50
120° Corner / 90° Ends	51
120° Corner / 120° Ends	52

PRIVACY SCREENS

Modesty Panel, Laminate	53
Privacy Screen, Fabric	54
Privacy Screen, Marker Board	55
Privacy Screen, Laminate	56
Worksurface Mounted Screens, Clear	57
Worksurface Mounted Screens, Frosted	58
Worksurface Mounted Screens, Fabric	59

MOBILE PEDESTAL

Mobile Pedestal	60
Keyed Alike	61

MONITOR ARMS

Monitor Arms	62
--------------	----

TABLE POWER COMPONENTS

Power Grommet	63
Power Distribution	64

ACCESSORIES

Wire Manager	65
Mesh Wire Manager	65
Casters	65
Conversion Kit	65
Desk Mounted Power Unit	65

SPECIFY BEAM

Beam Package with power & data cutouts	73
Beam Package without cutouts	74
Supporting Post - Inline & End of Run	75
Supporting Post - 2, 3, 4 Way	76
Laminate Insert Package	77
Base Cover, non-powered	79
Beam Package Top Caps	80
Electrical Distribution	81
Beam Mounted Screens	83

WORKSURFACES FOR USE WITH BEAM

Rectangular	85
Corner	86
90° Extended Curved Corner	87
Rectangular Extension	89
D-Shaped	90
Wedge	91
120° Corner / 90° Ends	92
120° Corner / 120° Ends	92

Terms and Conditions

PRICES

Pricing is delivered, freight included to 48 contiguous states. Specific requirements apply, minimum order required, see freight policy for details. See complete freight rules and policy on www.friant.com.

ORDERING

Purchase Orders should be sent to orders@friant.com or faxed to (510) 535-6895. If your specifications were created with CAP, GIZA or Project Matrix, please send the worksheet (.SP4, or .SIF) with your Purchase Order.

TERMS

Net 30 days from date of invoice. Invoices are delinquent if not paid 30 days from date of invoice. In the event timely payment is not made, interest will be charged at the rate of 1.5% per month on delinquent accounts. Buyers will also be liable for normal collection costs and attorney's fee. 50% deposit is required with every order, unless prior arrangements have been made.

ORDERS

Orders are only accepted by issuance of our formal acknowledgment, and are subject to the terms set forth herein and on our order acknowledgment. It is the responsibility of the buyer to review our acknowledgment for accuracy.

LEAD TIME

Lead times are subject to availability, see www.Friant.com for details.

SHIPPING

Friant generally palletizes, boxes and/or shrink-wraps its products. If buyer requests additional packaging or special shipping, then it is responsible for any extra costs that result. Buyer obtains title to products and assumes the risk of loss for them upon shipment from Friant's plant.

CLAIMS

We are not responsible for damage suffered in transit. Merchandise should be inspected for possible freight damage upon delivery. The consignee should file for damage or shortages with the carrier within 5 days of delivery. You are also protected for "concealed damage" if you file claim with the carrier within 5 days of delivery. Buyer must make all claims against Friant for defects, errors or shortages in writing within 10 days after delivery. Failure to make such a claim shall constitute full acceptance.

RETURNS

No merchandise may be returned without our written consent and shipping instructions. Unauthorized returns will not be accepted and will be returned freight collect.

PARTIAL SHIPMENTS

We will make every attempt to ship orders complete and on schedule. However, we reserve the right to make partial shipments, as merchandise is ready. Invoices covering these shipments are to be paid as they become due.

ORDER CHANGE/CANCELLATIONS

Our order confirmation is final and binding. Any order change or cancellation is subject to our ability to conform. For the most up to date information, always review the order change/cancellation policy online. Allowable changes within the posted policy must be made in writing.

SHIPMENT AND PREPAID FREIGHT

Unless otherwise instructed, we reserve the option to ship by what is, in our opinion, the best possible way. Upon request, we will prepay and add freight for accounts with established credit.

DELIVERY

We are not liable for delay or failure of delivery due to strikes and/or differences with workmen, war, riot, fire, compliance with government regulations, acts of nature, failure or delays of sources of supply, or any other causes beyond our control.

STORAGE

If buyer cannot accept delivery when merchandise is ready, we reserve the right to transfer goods to storage. Costs of transfer and storage will be charged to the buyer's account, and we will deem such transfer as constituting shipment for all purposes, including invoicing, as of the date the transfer is made.

Terms and Conditions

CONSTRUCTION — SPECIFICATIONS

All items are produced to price list specifications unless otherwise advised. All dimensions shown are approximate. Manufacturer reserves the right to make modifications and/or improvements without prior notice.

FABRIC APPLICATION

Standard fabric application is non-directional. Friant & Associates is not responsible for charges associated with replacement of products due to incorrect specifications. Certain product construction and sizes require fabric to be applied only Directionally or Non-Directionally. See individual pricebook specifications for details.

CUSTOMER'S OWN MATERIAL

Yardage requirement is based on 66" wide plain covering material, and must be increased if less than 66" wide. Special instructions for handling material (pattern, directional fabric, right side of reversible fabric, etc.) must be submitted in writing before fabric is delivered. In the absence of special instructions, we reserve the right to use our own judgment. We reserve the right to reject any covering, which in our opinion, is unsuitable for our upholstery purposes. However, in no instance shall we be held responsible for unsatisfactory results due to use of covering unsuitable for our upholstery methods.

We will not be responsible for errors caused by buyers not supplying us with sample cuttings attached to their order giving full identification of covering material, (name of supplier, covering name, number and color) for identification purposes and advising us of model number and quantity to which each cover is to be applied.

Customer's own material that is shipped freight collect will be refused. A service charge will be applied for the return of unusable C.O.M. Contact factory.

RIGHTS AND WARRANTIES — 5 YEARS

This warranty is given to the initial purchaser and is valid from the date of purchase, for as long as the initial purchaser owns the product. This warranty covers defects in material and craftsmanship found during normal usage of the product during the warranty period. Normal usage is defined by 8 hour shifts in the product's intended application and in an indoor environment that conforms to the ANSI/ASHRAE Standard 55: Thermal Environmental Conditions for Human Occupancy (relating to air temperature, mean radiant temperature, air velocity, clothing insulation, metabolic rate, and humidity). Friant's warranty does not cover usage other than normal usage as defined in the previous sentence. If the product is defective, and if written notice of the defect is given to Friant & Associates within the applicable warranty period, Friant & Associates, at its option, will either repair or replace the defective product with a comparable component or product. This warranty applies to all products except as noted below.

The following exceptions to the limited 5 year warranty apply: All Motors and electrical components are warranted for 5 years.

High wear parts, such as wood veneer, fabrics, laminates and other covering material/finishes, foam, glides, etc. are warranted for one (1) year. This warranty does not apply to damage caused by a carrier, alteration to the product not expressly authorized by Friant & Associates, nor to product considered to be of a consumable nature such as bulbs, light ballasts, etc. It also does not apply to "Customer's Own Material" (i.e. material specified by the customer that is not a standard Friant & Associates offering) used in the manufacture of Friant & Associates products.

Our warranty for LED lights is 2 years.

Friant & Associates does not warrant the matching of colors, grain or texture, except to within commercially acceptable standards. This includes normal variations between dye lots (fabrics).

A product will not be considered defective, and Friant & Associates will not be obligated to replace it, if it is not installed in a proper manner (i.e. product not leveled, not secured properly, etc.) or if it is not used in a manner and/or in an environment that constitutes normal usage, as defined above.

Except as noted above, Friant & Associates makes no express or implied warranties to any product, and in particular makes no warranty of fitness for any particular use. At Friant & Associates' option, product repair and replacement is the customer's exclusive remedy for any and all product defects.

Friant & Associates shall not be liable for consequential, economic, or incidental damages arising from any product defect.

Terms and Conditions

CALIFORNIA PROP 65 WARNING

Products in this catalog can expose you to chemicals including wood dust, which is known to the State of California to cause cancer or birth defects or other reproductive harm. For more information go to <https://www.p65warnings.ca.gov/products/furniture-products>.”

CARB

Friant products are CARB 93120 compliant for formaldehyde (phase 2)

TSCA TITLE VI

Friant products are TSCA Title VI Compliant

MAS

Accredited Compliance Designation - ANSI/BIFMA x7.1 & e3-2014 7.6.1, 7.6.2, 7.6.3

California Dept. Of Public Health Standard Method v1.2

Conforms With: LEED v4

Criteria of MAS Certified Green ® Program

Standard Fabrics

JOURNEY		TERRAIN		SLIDE		SILKY		SKY	
PF801-1	Quest	PF701-1	Cloud	PF101-1	Caramel	PF401-1	Natural	PF301-1	Terra
PF801-2	Voyage	PF701-2	Dusk	PF101-2	Slate	PF401-2	Parids	PF301-2	Birch
PF801-3	Transit	PF701-3	Wave	PF101-3	Pewter	PF401-3	Overcast	PF301-3	Moss
PF801-4	Amble	PF701-4	Earth	PF101-7	Java	PF401-5	Graphite		
PF801-5	Odyssey			PF101-9	Sterling				
PF801-6	Caravan			PF101-10	Crema				
PF801-7	Expedition			PF101-13	Mustard				
PF801-8	Wayfare			PF101-14	Avocado				
				PF101-15	Pumpkin				
				PF101-16	Ocean				
				PF101-17	Blueberry				
				PF101-18	Cardinal				
				PF101-19	Flamingo				
				PF101-20	Serenity				
				PF101-21	Azure				
				PF101-22	Orchid				
				PF101-23	Plum				
				PF101-24	Raven				

LIMITED AVAILABILITY

SLIDE		SILKY		STICKS		PASSAGE	
PF101-4	Verde	PF401-4	Field	PF501-3	Sage	PF601-1	Gull
PF101-6	Vintage			PF501-4	Straw	PF601-2	Grove
PF101-8	Latte					PF601-5	Leaf
PF101-12	Stem					PF601-6	Brook
						PF601-7	Trail
						PF601-8	Amber

Fabric is scheduled for discontinuation when inventory is exhausted. Please contact Customer Service for current stock levels. After discontinuation fabric will be available with extended lead time, subject to minimum yardage requirements.

NOTES:

- Passage and Terrain are not available on acoustical panels, pedestal cushions, tackboards or fabric screens.
- Please refer to the Fabric Direction Section in the Materials Reference Guide on the Dealer Resource Center for more details: <http://dealers.friant.com/dealers/product-literature/>
- Order fabric / finish sample online at www.friant.com
- Colors may vary slightly between dye lots.

Pattern Direction

- Fabric direction is not always determined by the way the pattern is shown on memo sample.
- Certain product construction and sizes require fabric to be applied only Directionally or Non-Directionally.
- Some products have fabric applied either Directionally or Non-Directionally. (Upcharges may apply on some products, see price books for details).
- Please refer to our Materials Reference Guide on the Dealer Resource Center for specific pattern application defaults on all of our products : <http://dealers.friant.com/dealers/product-literature/>
- Our Customer Service Team is happy to answer any questions regarding fabric direction.

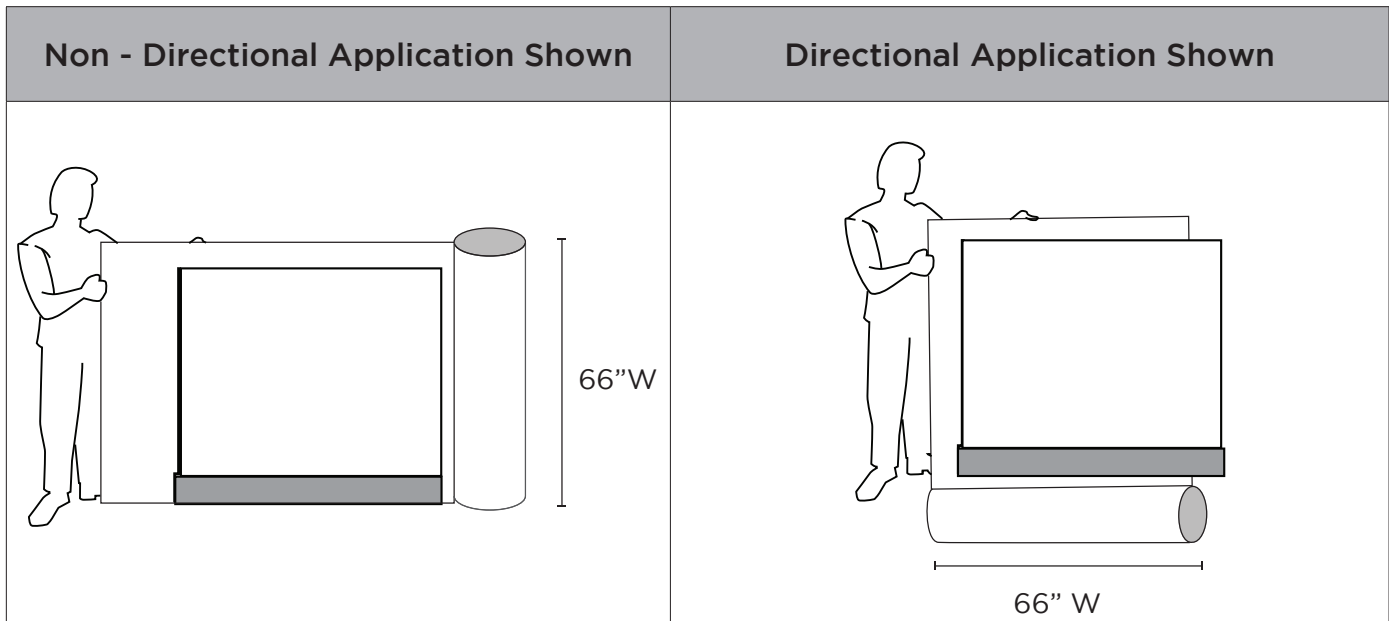

Standard Finishes

Order samples at www.friant.com/samples

Please Note: Images are printed simulations and are not exact matches of finished product. Please request an actual sample from Friant or your sales consultant before specifying finishes.

For matching edge PVC, please read across matrix.

WORKSURFACE LAMINATES

EDGE LAMINATES (3MM PVC)

M1	Light Maple	E1	Light Maple
M2	Light Cherry	E2	Light Cherry
M3	Medium Cherry	E3	Medium Cherry
M4	Dark Mahogany	E4	Dark Mahogany
M5	Light Mahogany	E5	Light Mahogany
M6	Light Gray	E6	Light Gray
M7	Off White	E7	Off White
M8	Gray Specks	<i>*See complimentary edge finishes below</i>	
M9	Cloud White	E9	Cloud White
M10	Espresso	E10	Espresso
M11	Light Walnut	E14	Light Walnut
M12	Medium Walnut	E15	Medium Walnut
M13	Licorice	E13	Licorice
M14	Carob	E17	Carob
M15	Mousse	E18	Mousse
M16	Tundra	E19	Tundra
M17	Cocoa	E20	Cocoa
M18	Capitan	E21	Capitan
M19	Fog	E22	Fog
M20	Sandstone	E23	Sandstone
M21	Medium Oak	E24	Medium Oak
M22	Harbor	E25	Harbor
M23	Bark	E26	Bark
M24	Tarmac	E27	Tarmac
M25	Winter	E28	Winter
M26	Storm	E29	Storm
M27	Medium Ash	E30	Medium Ash
M28	Arctic	E31	Arctic
M29	Raven	E32	Raven

*Complimentary Edge Finishes	
E8	Black Umber
E12	Dark Tone
<i>*Complimentary edge finishes have no exact laminate match available</i>	

Note: For other worksurface finish, please consult your Friant sales consultant.

PAINT TRIM

- CW Cloud White
- BU Black Umber
- SV Silver

STANDARD GROMMET FINISHES

- CW Cloud White
- BU Black Umber
- SV Silver

POWER GROMMET FINISHES

- BA Brushed Aluminum
- BC Brushed Charcoal
- CW Cloud White

FOAM CUSHION

- Green
- Blue
- Red
- Charcoal
- Café
- Grey

COLOR PEDESTAL TOP

- Green
- Blue
- Red

Grommet Locations, My-Hite Tops

1 Select a My-Hite worksurface

My-Hite tops (see page 42) offer optional grommets. (Please use the codes shown when specifying location of grommets). An upcharge of \$75 applies for cutouts.

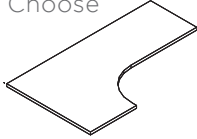
Choose	Specify Part #	Specify worksurface and edge
	FCCAHS-24366024R	M15 Mousse E18 Mousse

2a Select a grommet location (Straight & extended corner 90° tops)

Specify location by using the two letter code.

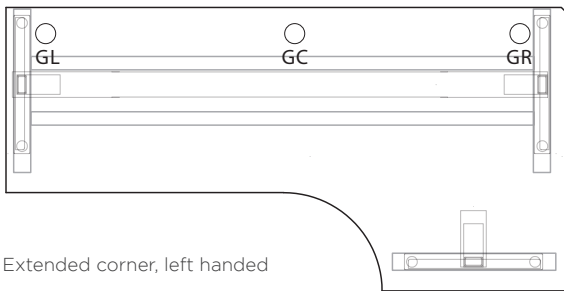
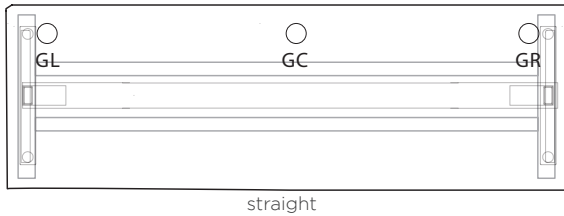
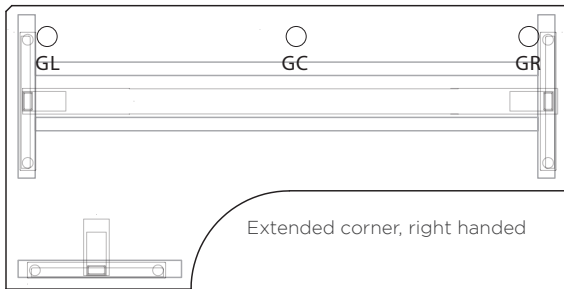

CODE	POSITION
GL	4" from left side - 4" from rear
GR	4" from right side - 4" from rear
GC	Centered from side to side - 4" from rear

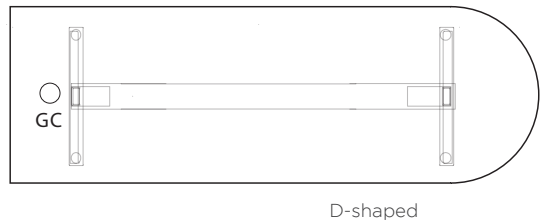

Dimensions are measured from grommet center

For other grommet locations, please call Friant customer service.

Grommets are 3" round with cover standard

Please Note: Only the GC location is available on the D-Shaped worksurface.

Base position will vary with 72", 78" and 84" worksurface length.

Grommet Locations cont'd

2b Select a grommet location, 120° Tops

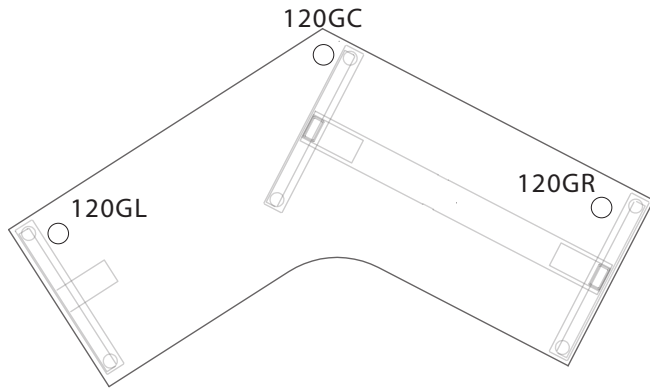

CODE	POSITION
120GL	4" from left side - 4" from rear
120GR	4" from right side - 4" from rear
120GC	Centered from side to side - 4" from rear

Dimensions are measured from grommet center
 For other grommet locations, please call Friant customer service.
 Grommets are 3" round with cover standard

2c Select a grommet location, 90° Equal Corners

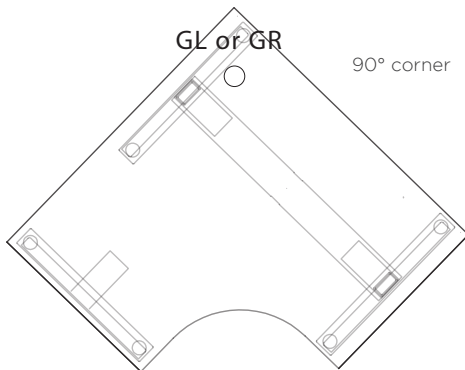

CODE	POSITION
GL or GR	4" from from corner

Dimensions are measured from grommet center
 For other grommet locations, please call Friant customer service.
 Grommets are 3" round with cover standard

Power Grommet Locations - Notch Cutouts, My-Hite Worksurfaces

FRIANT Power Grommet notch cutouts are required when specifying a Power Grommet on a worksurface supported by a My-Hite C-Leg adjustable height table base. Choose the size of power grommet (5x8 only) and cutout location (left, center or right). Specify Power Grommets on page 14. An upcharge of \$75 applies for cutouts.

NOTE: Notch cutouts only available with 5x8 Power grommets and C-leg bases.

1 Select a My-Hite worksurface

My-Hite worksurfaces (starting on page 36)

2 Select a power grommet notch cutout location

Less than 72"

CODE	POSITION (Specific to worksurfaces 72" and below)
PG5L-C	4.5" from left side
PG5C-C	Centered
PG5R-C	4.5" from right side

Over 72"

CODE	POSITION (Specific to 78" and 84")
PG5L-C	11" from left side
PG5C-C	Centered
PG5R-C	11" from right side

Less than 72"

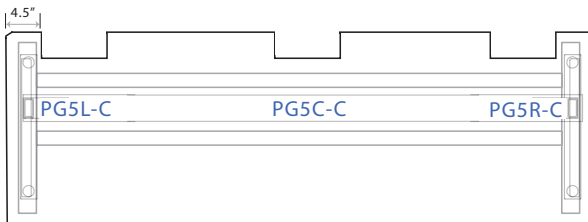

Over 72"

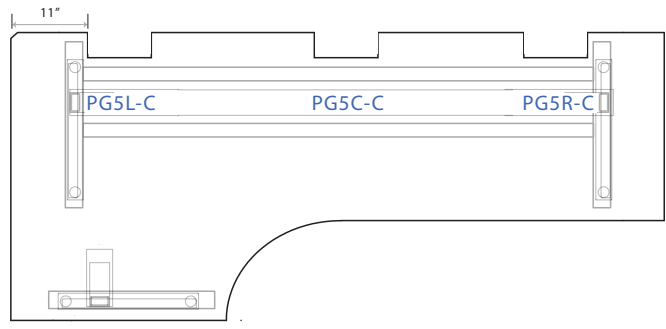
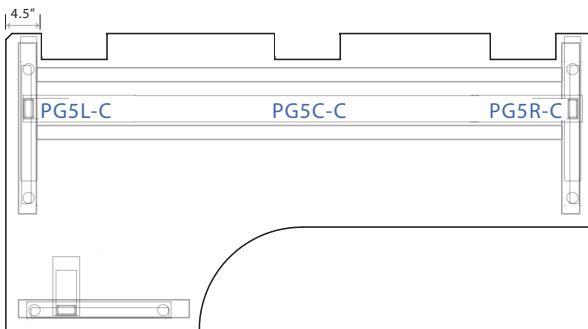
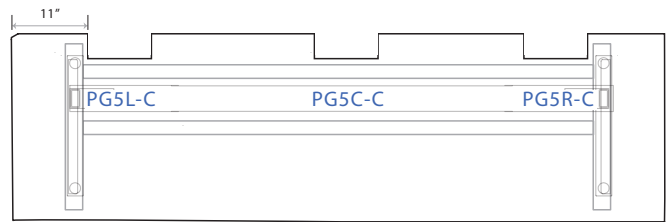

Less than 72"

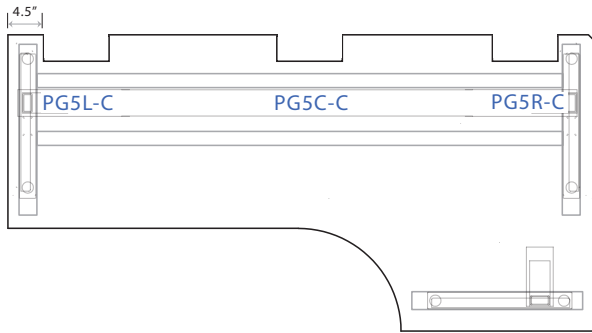

Over 72"

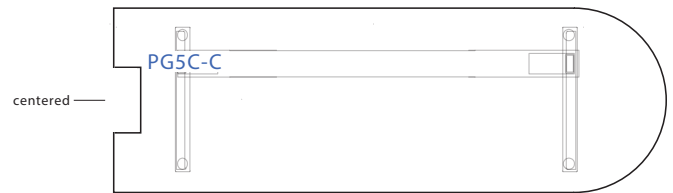
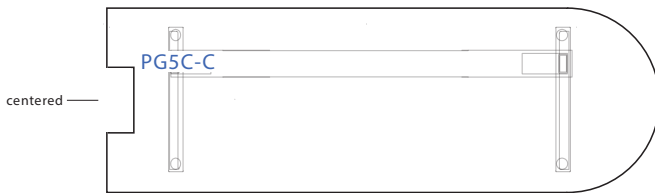
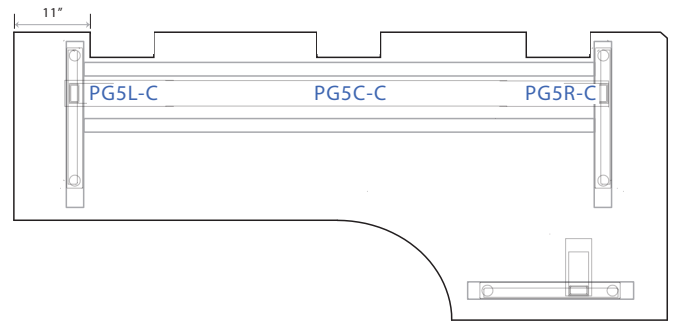

Positions for 120° worksurfaces:

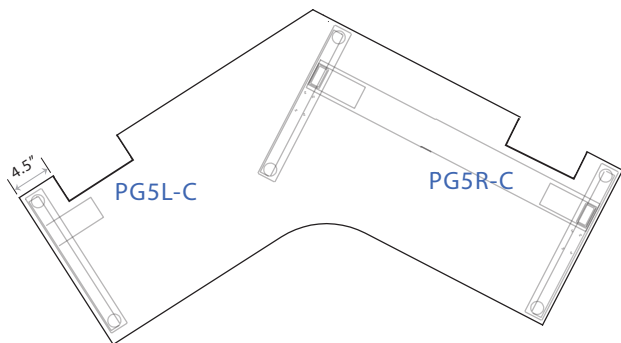

Positions for 90° equal corner worksurfaces:

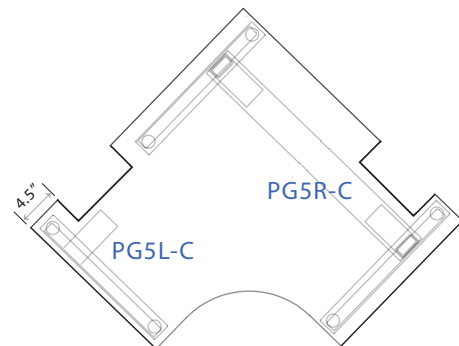

Power Grommet Locations - Interior Cutouts, My-Hite Worksurfaces

FRIANT Power Grommet interior cutouts are used when specifying a Power Grommet on a worksurface supported by a My-Hite T-Leg adjustable height table base. Choose the size of power grommet (5x8 or 6x8) and cutout location (left, center or right). Specify Power Grommets on page 16. An upcharge of \$75 applies for cutouts.

NOTE: Standard position Interior cutouts are not compatible with C-leg bases.

1 Select a My-Hite worksurface

My-Hite worksurfaces (starting on page 36)

2 Select a power grommet interior cutout location

Less than 72"

CODE	POSITION (Specific to worksurfaces 72" and below)
PG6L	4.5" from left side, 1.5" from back
PG6C	Centered, 1.5" from back
PG6R	4.5" from right side, 1.5" from back
PG5L	4.5" from left side, 1.5" from back
PG5C	Centered, 1.5" from back
PG5R	4.5" from right side, 1.5" from back

Over 72"

CODE	POSITION (Specific to 78" and 84")
PG6L	11" from left side, 1.5" from back
PG6C	Centered, 1.5" from back
PG6R	11" from right side, 1.5" from back
PG5L	11" from left side, 1.5" from back
PG5C	Centered, 1.5" from back
PG5R	11" from right side, 1.5" from back

120° and 90° worksurfaces

CODE	POSITION (Specific to 120° and 90°)
PG6L	4.5" from left side, 1.5" from back
PG6C	Centered, 1.5" from back
PG6R	4.5" from right side, 1.5" from back
PG5L	4.5" from left side, 1.5" from back
PG5C	Centered, 1.5" from back
PG5R	4.5" from right side, 1.5" from back

Less than 72"

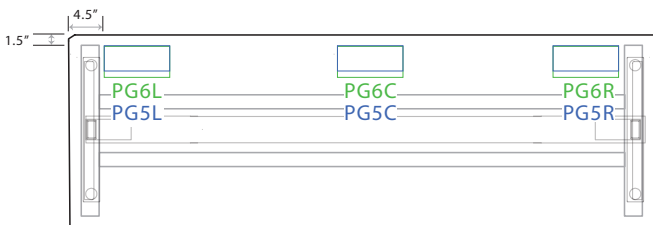

Over 72"

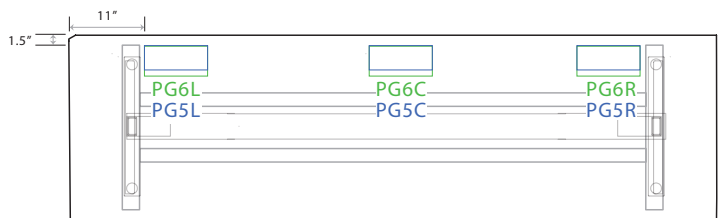

Less than 72"

Over 72"

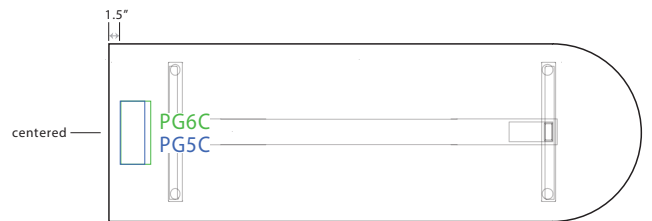
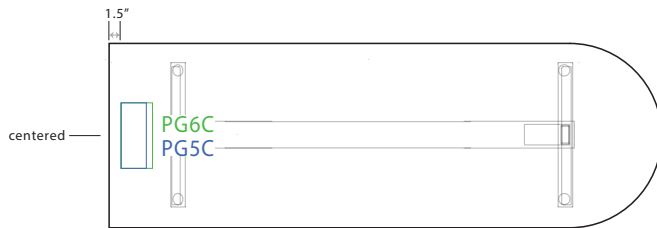
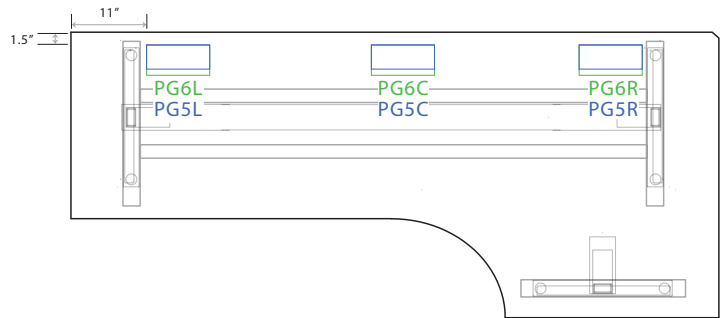
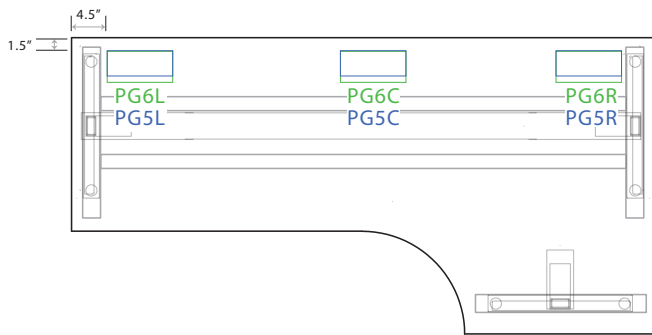
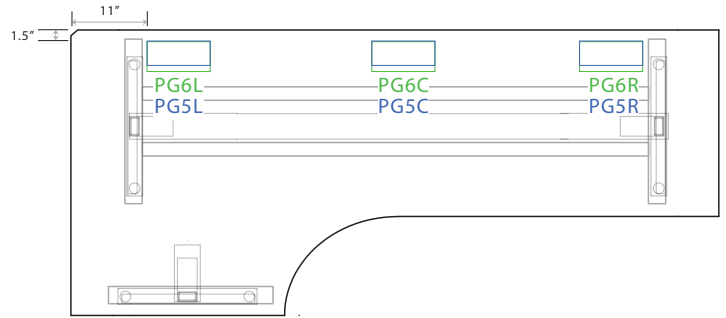
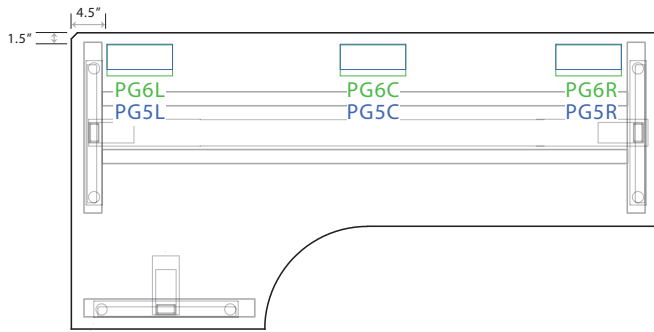

Positions for 120° worksurfaces:

Positions for 90° equal corner worksurfaces:

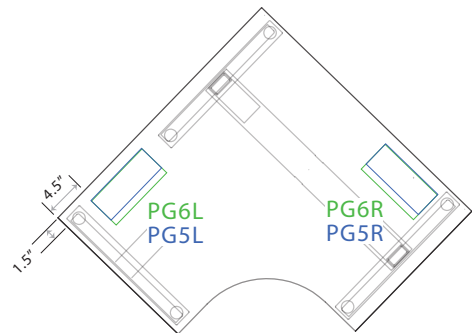
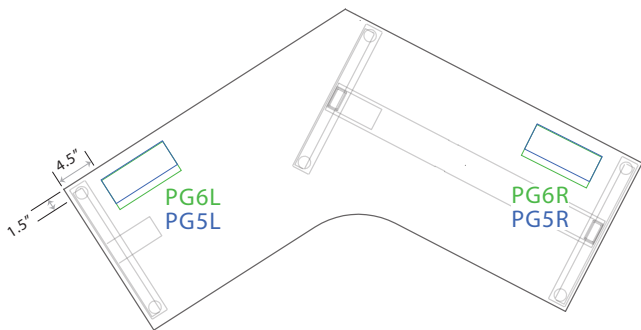

Power Grommet

FRIANT power grommets are available to meet different worksurface power and data needs. Choose the color of the power grommet (brushed aluminum, brushed charcoal, or cloud white). Specify power grommets on page 63 .

3 FINISHES AVAILABLE

Brushed aluminum, brushed charcoal and cloud white

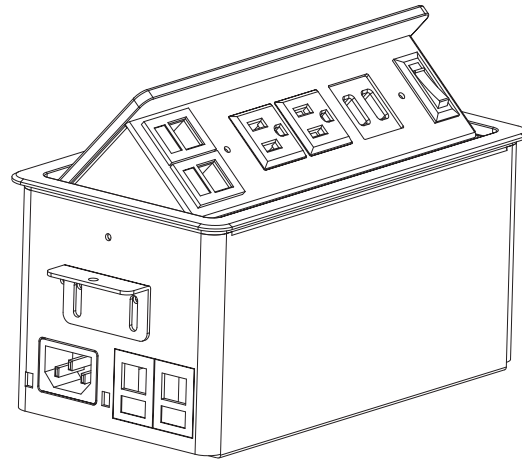
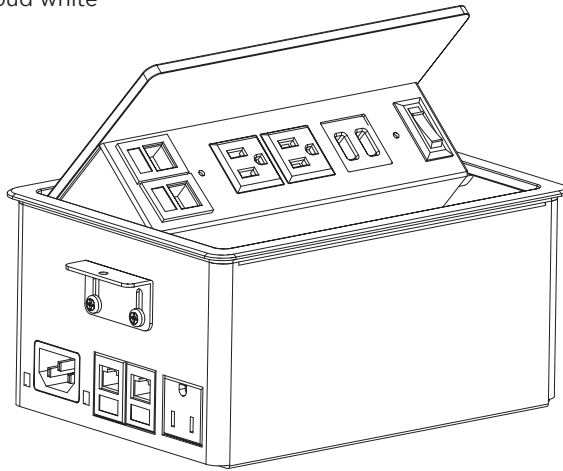

INCLUDES SPRING CORD

(Not shown) For connection to power source

POWER GROMMETS

6x8

- (2) CAT6 Data Ports
- (4) Power Outlets
- (2) USB Ports

5x8

- (2) CAT6 Data Ports
- (3) Power Outlets
- (2) USB Ports

How To Specify My-Hite 2-Piece Extended Corner or Rectangular Tops

Use a FVFB.08 Flat Bracket pair to attach the two surfaces, making sure the seam is oriented so that it is supported by the continuous part of the My-Hite Corner Base. Maximum width combined: 72x96" or 84x84". Specify the Rectangular Extension on page 97.

To create an extended corner My-Hite station, specify an Extended Curved Corner with a Rectangular Extension.

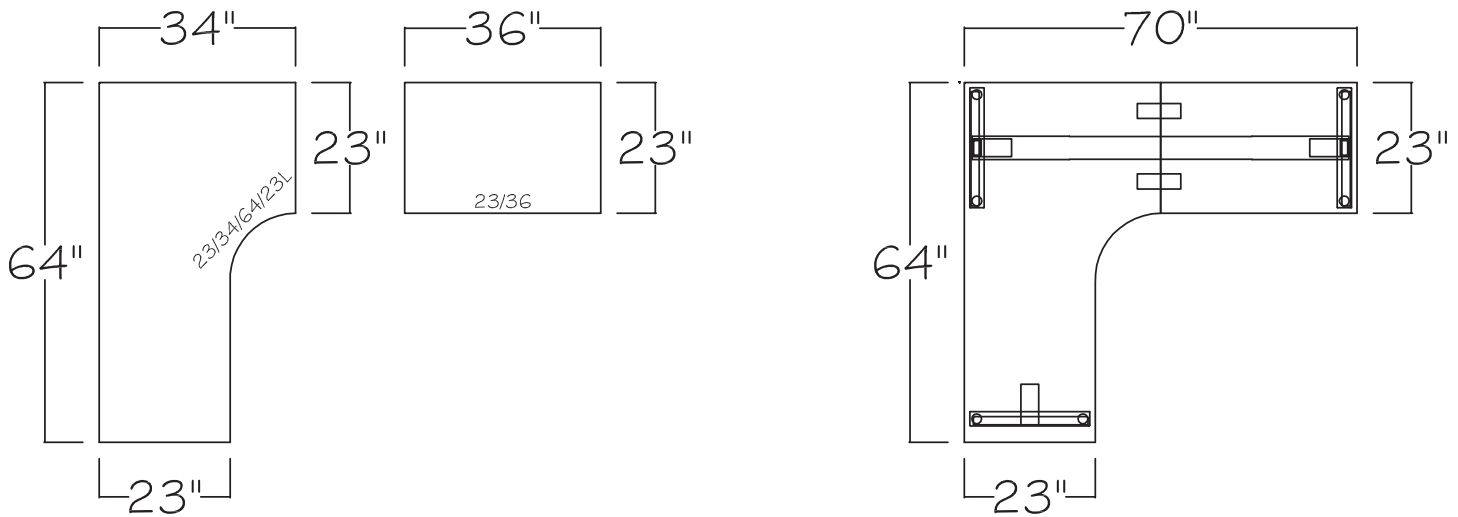

To create a two piece rectangular corner top, specify two rectangular tops, or a rectangular top and one rectangular extension.

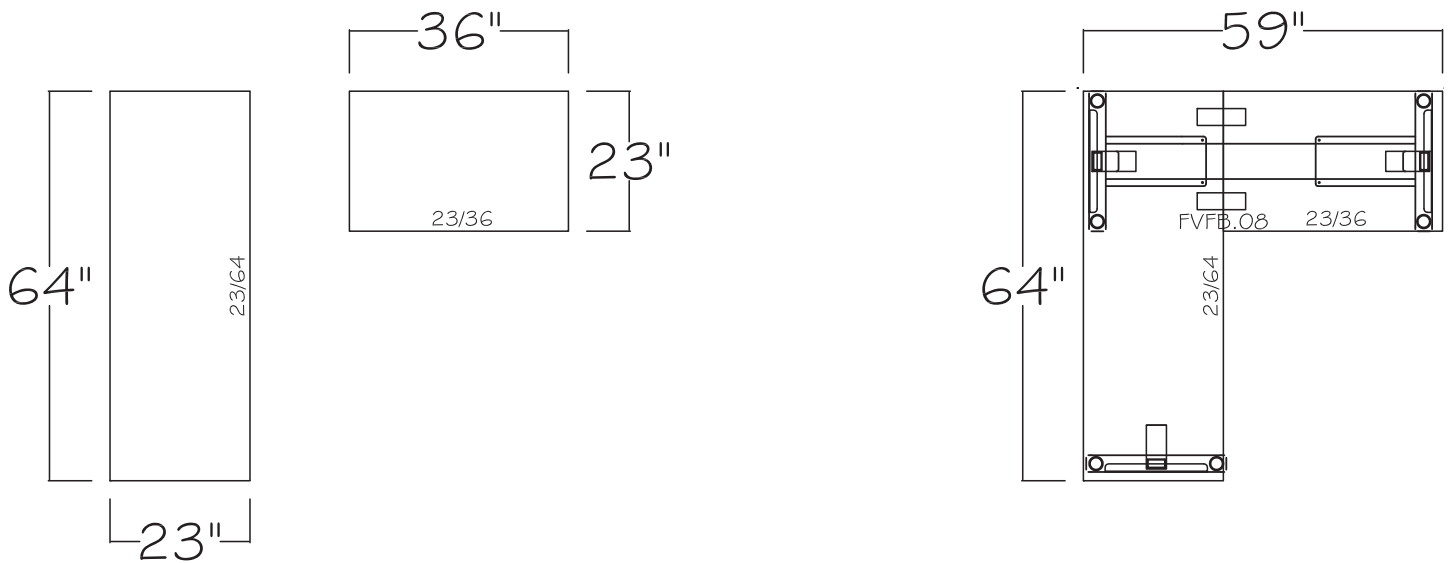

Mobile Pedestals

FRIANT pedestals are available in a variety of options to meet different storage needs. Choose the color of the pedestal (cloud white, black umber, and silver), and, as options, the color of the optional foam cushion (green, café and charcoal) and the color of the top cap (red, green and blue). Pedestals include pencil tray, mail slot and keyed alike options for locks. Front to back file bars are included.

BOX/FILE MOBILE PEDESTAL
Top of pedestal is finished

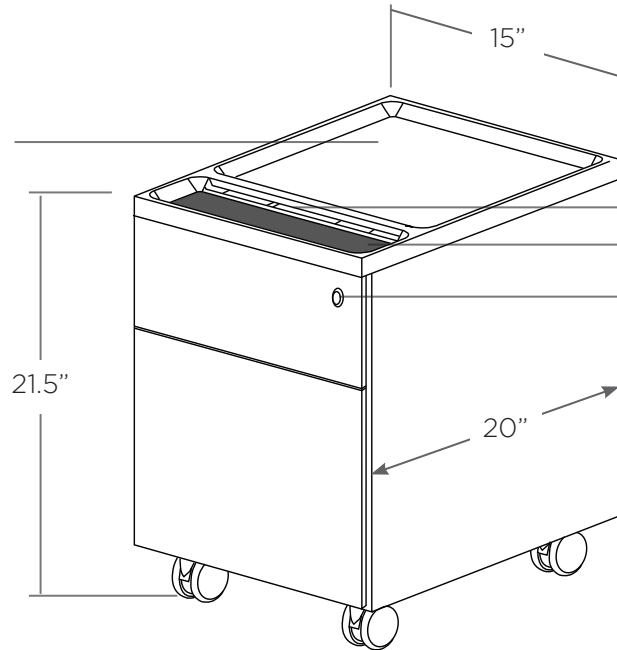

- MAIL SLOT**
- PENCIL TRAY**
- LOCKING**
Keyed alike option is available. (page 60)

BOX/FILE PEDESTAL
Ships standard with (2) locking and (2) non-locking casters.

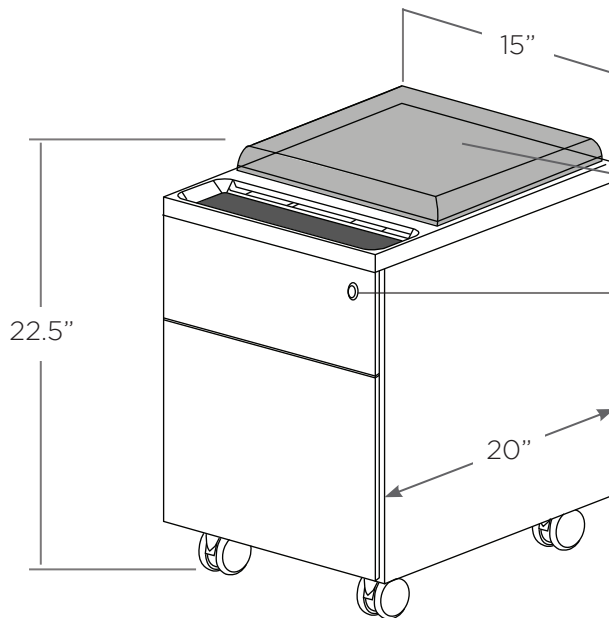

OPTIONAL FOAM CUSHION
Mobile pedestals can be topped with a foam cushion.

LOCKING
Keyed alike option is available.

FRONT TO BACK FILE BAR
ship standard.

Freestanding Application Example of My-Hite

As a Standalone

- Order Base (page 32 or 19)
- Order Top (page 42)

Note: Dimensions are actual for standalone tops

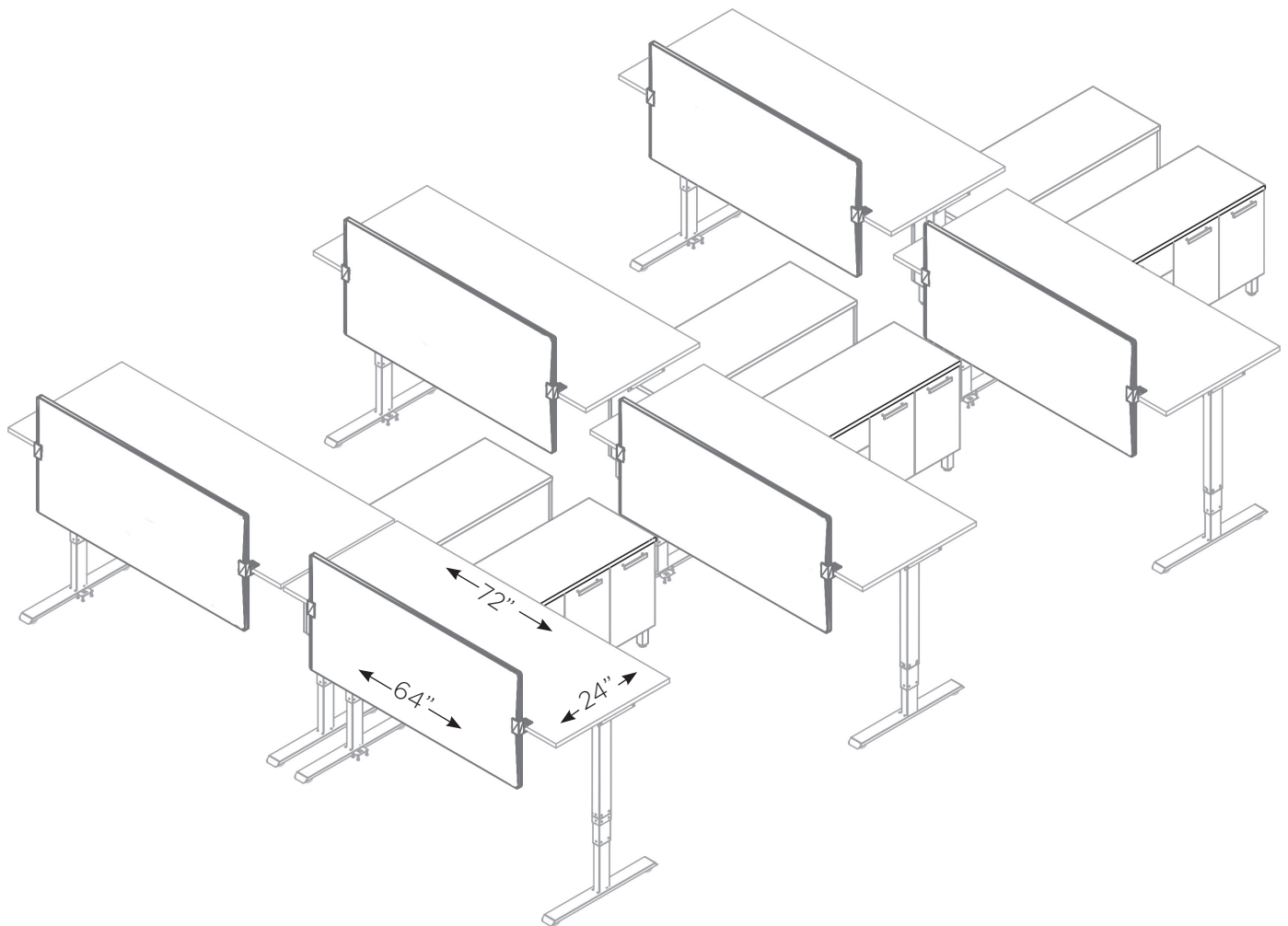

Freestanding Workstation Example

- **Base:** FSQAHBT-24-3

3 stage base range 24.5"-50", page 32

- **Worktop:** FSQAHT-2472

Rectangular worksurface, page 42

- **Privacy Screen:** FPSFLUSH.2472

Fabric covered privacy screen, page 54

- **Credenza:** FCREDSQAP.48L

Freestanding credenza, Novo Pricebook, page 82

Workstation Application Example of My-Hite (Interra)

As part of a Workstation

- Order Base (page 32 or 19)
- Order Top within System Pricebook
 - System 2 - Novo
 - Dash - Intera
 - Verity

Note: Top size reduced 1" in depth and 2" in width to fit within system workstation and prevent pinch points. See system pricebook for details. We do not recommend using full size worktop in paneled workstation applications.

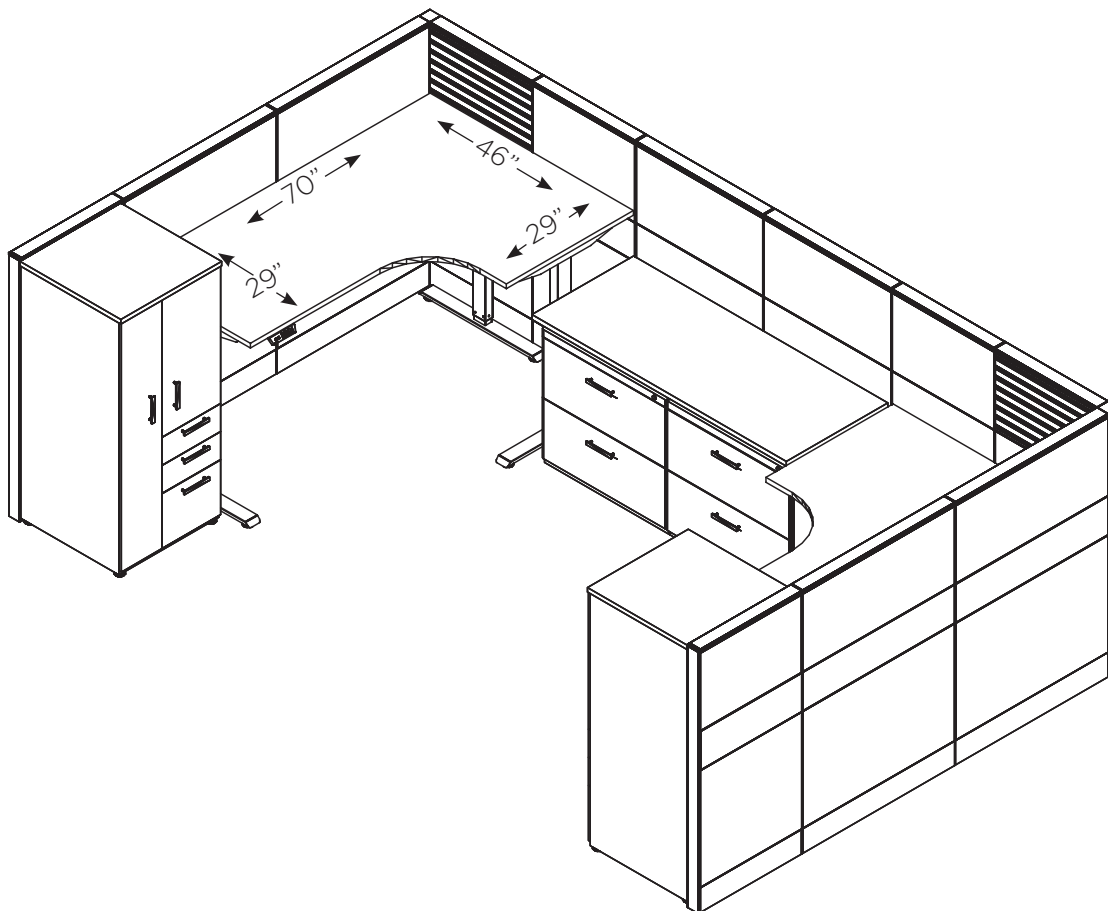

Interra Workstation Example:

- **Base:** FCNAHB-24-3
3 stage base range 24.5"-50", page 34
- **Worksurface:** FIECCWS.29467029 L/R
Corner worksurface top only. For use with height adjustable base within workstation application - Interra Pricebook, page 70

Beam Application Example of My-Hite

With Beam Application

- Order Base (page 32 or 19)
- Order Top (page 85)

Note: Top size reduced 1" in depth and 2" in width to fit with beam application and prevent pinch points. See page 85. We do not recommend using full size worktops with beam application.

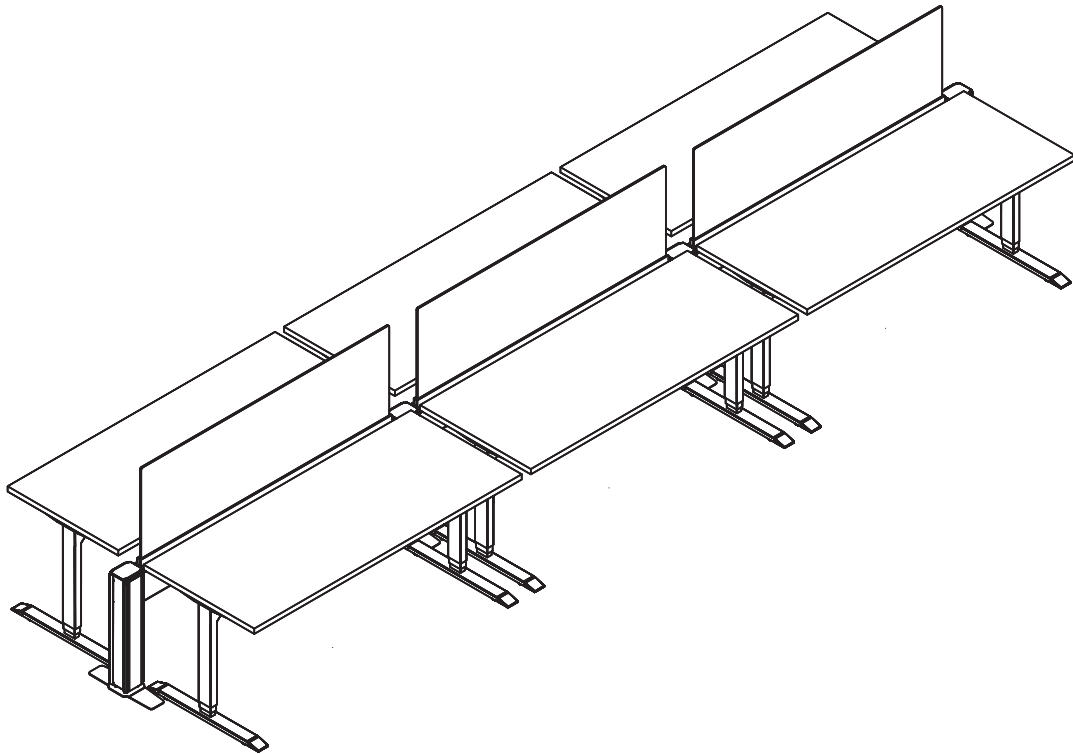

Beam Workstation Example:

- **Base:** Straight Base
3 stage base range 24.5"- 50", page 32
- **Worksurface:** FBRWS.2370
Straight worksurface top only. For use with height adjustable base within beam application.- page 85

Base Application — 3 stage

Worksurface depth

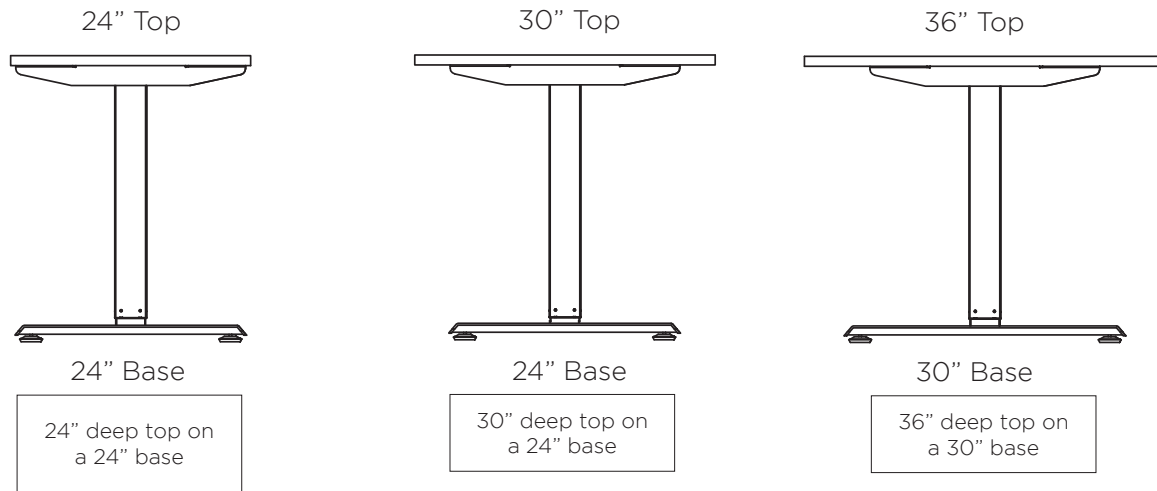

Electrical Draw of My-Hite — 3 stage

TABLE	MOTION	WATTS	AMPS
ONE (1) ADJUSTABLE TABLE	START UP DRAW	-	< 5 AMP
ONE (1) LOADED ADJUSTABLE TABLE	RUNNING DRAW	100W	4.16 AMP
ONE (1) EMPTY ADJUSTABLE TABLE	RUNNING DRAW	50W	2.08 AMP
ONE (1) ADJUSTABLE TABLE (NOT IN MOTION)	DRAW	-	0 AMP

Trough Cover Dimensions — 3 stage

Fixed trough cover is 2.5" tall and 8" deep

T Style Base
72" width tops shown

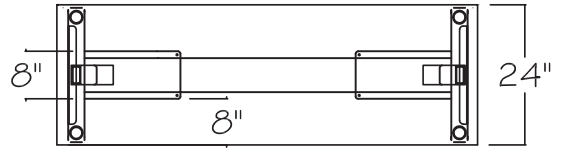
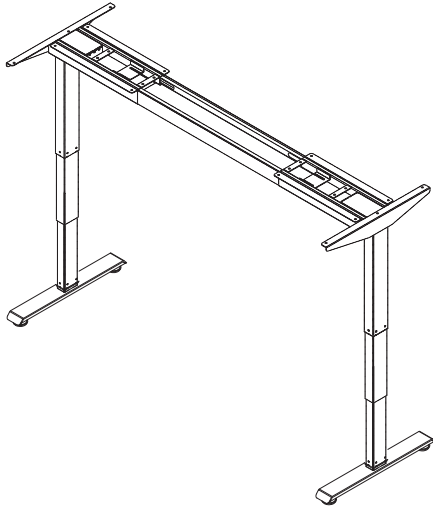

24" D top on 24"D base

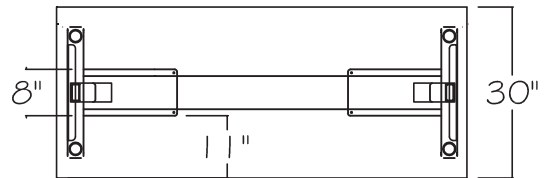

30" D top on 24"D base

C Style Base
72" width tops shown

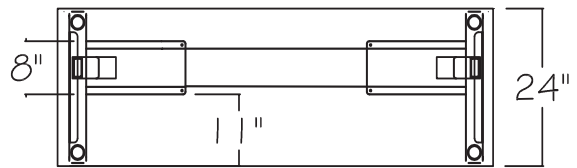
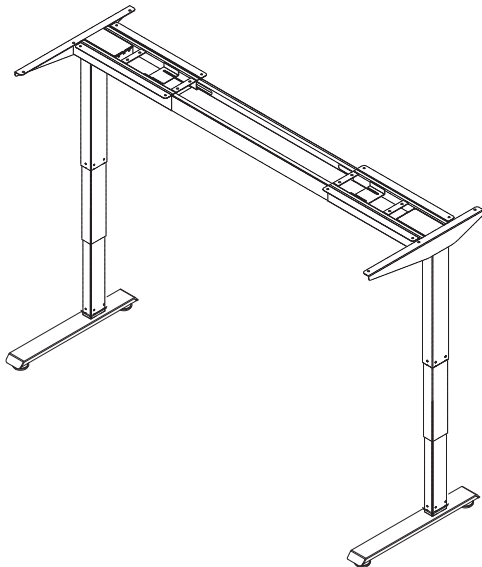

24" D top on 24"D base

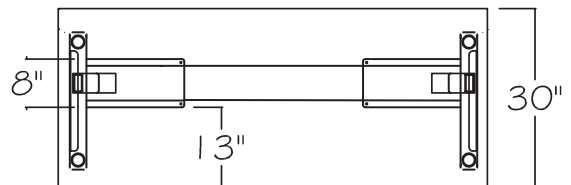

30" D top on 24"D base

Recommended Top Application — 3 stage

Corner Worksurfaces

1 120° Tops

NOTES: 120° corners - use straight base on 36" and 42" wide worksurfaces.
Use corner base on worksurfaces 48" or larger.

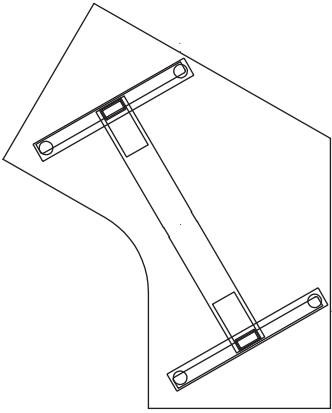

36" Top
(Straight Base)

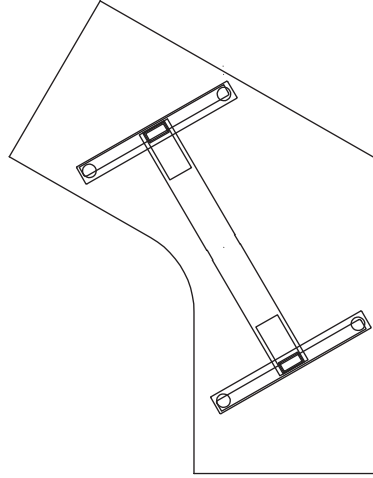

42" Top
(Straight Base)

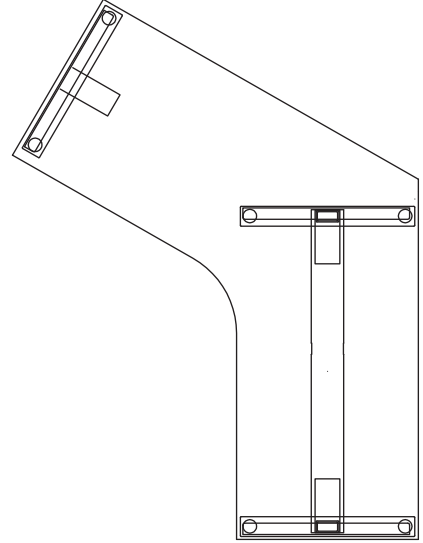

48" Top
(Corner Base)

2 90° Tops

NOTES 90° corners - use straight base on 48" worksurfaces only.
Use corner base on 42" or extended corners.

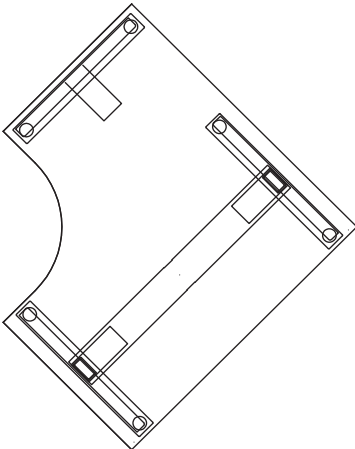

42" Top
(Corner Base)

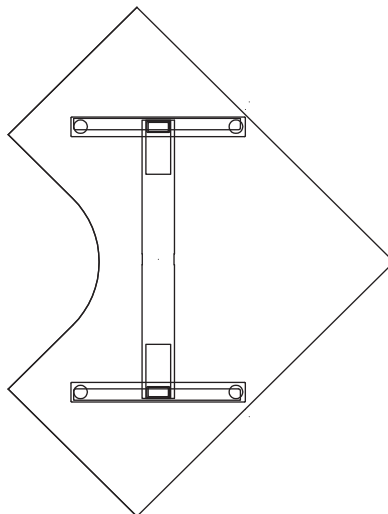

48" Top
(Straight Base)

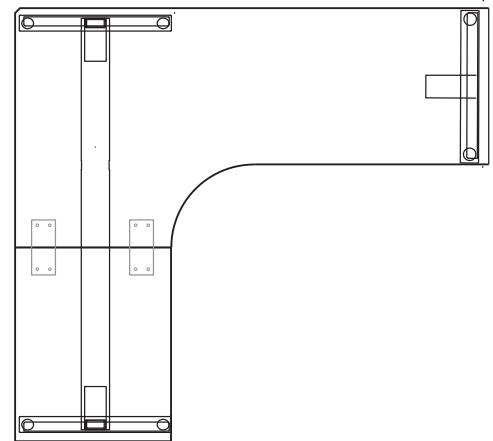

72X72" Top
(Corner Base)

Technical Specifications — 3 Stage

Straight Legs

See pages 32-33

Display	Digital display with three programmable presets
Foot Length in inches	22" and 28" available for 24" and 30", 36" worksurfaces
Legs	3 stage, available as T or C leg
Leg Post Size	2.75" x 2.75"
Height range (excluding top)	24.5"- 50"
Frame width expansion	Width extendable 38"- 68" in 1 mm increments
Worksurface widths	42" - 84", See pages 42 to 52
Worksurface depths	24", 30" and 36", See pages 42 to 52
Power Cord Length	9'
Max lifting capacity	220 lbs
Base weight without top	113 lbs
Gauge of Steel	Inner/Middle tubes: 2mm / Outer tube 2mm = 12 gauge
Speed	40 mm/s
Table Not In Motion, Electrical Draw	0 W
Loaded Running Table, Electrical Draw	200/360 W
UL	UL962

Technical Specifications — 3 Stage

Corner

See pages 34 to 37

Display	Digital display with three programmable presets
Foot Length in inches	22" and 28" available for 24" and 30", 36" worksurfaces
Legs	3 stage, available as as T or C leg
Leg Post Size	2.75" x 2.75"
Height range (excluding top)	24.5"- 50"
Frame width expansion	Width extendable 38"- 68" in 1 mm increments
Worksurface widths	42" - 84", See pages 42 to 52
Worksurface depths	24", 30" and 36", See pages 42 to 52
Power Cord Length	9'
Max lifting capacity	330 lbs
Base weight without top	113 lbs
Gauge of Steel	Inner/Middle tubes: 2mm / Outer tube 2mm = 12 gauge
Speed	40 mm/s
Table Not In Motion, Electrical Draw	0 W
Loaded Running Table, Electrical Draw	200/360 W
UL	UL962

Base Application — 2 stage

Worksurface depth

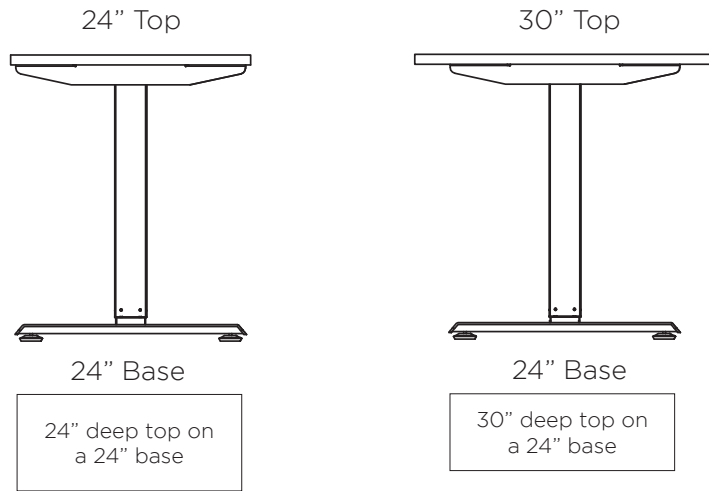

Electrical Draw of My-Hite — 2 stage

TABLE	MOTION	WATTS	AMPS
ONE (1) ADJUSTABLE TABLE	START UP DRAW	400W	< 5 AMP
ONE (1) LOADED ADJUSTABLE TABLE	RUNNING DRAW	400W	3 AMP
ONE (1) EMPTY ADJUSTABLE TABLE	RUNNING DRAW	200W	1.5 AMP
ONE (1) ADJUSTABLE TABLE (NOT IN MOTION)	DRAW	.3W	0 AMP

Recommended Top Application – 2 stage

Certain sizes of My-Hite tops can be used with 2 stage bases. See below for additional information.

**Rectangular
(Straight Base)**

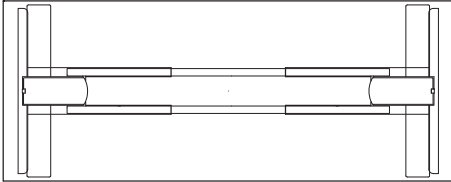

Depth: 23"/24", 29"/30"
 Width: Min - 42" (no 40")
 Max - 84"

**120° Corner
(Straight Base)**

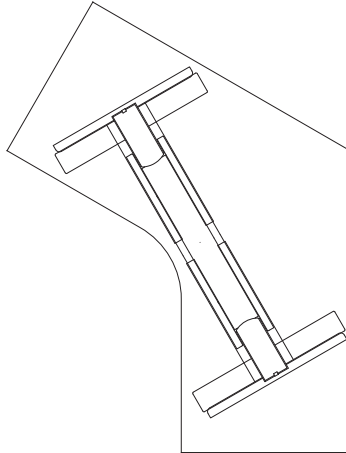

Width: Min - 36" (no 34")
 Max - 40"/42"

**90° Corner
(Straight Base)**

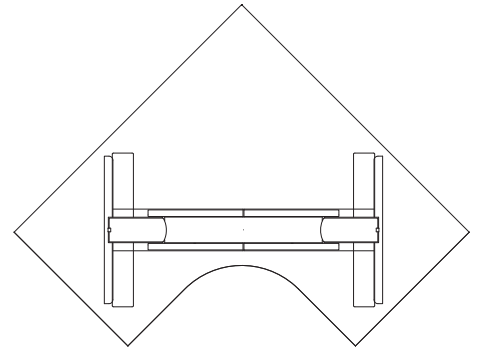

Depth: 23"/24", 29"/30"
 Width: Min - 46"/48" only

**Two Piece Rectangular
(Corner Base)**

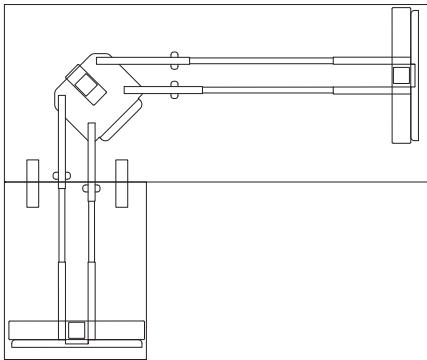

Depth: 23"/24", 29"/30"
 Width: Min - 58"x58"
 Max - 84"x84" or 72"x96"

**Two Piece Extended Curved
Corner (Corner Base)**

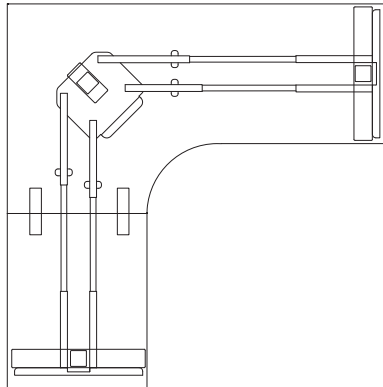

Depth: 23"/24", 29"/30"
 Width: Min - 58"x58"
 Max - 84"x84" or 72"x96"

Technical Specifications — 2 stage

Straight Legs

See page 39

Display	Digital display with four programmable presets
Foot Options	24" ONLY
Legs	T LEG
Leg Post Size	2.72" x 2.72"
Height range(excluding top)	27"- 45.5"
Frame width expansion	Width extendable 41"- 74" in 1mm increments
Worksurface widths	42"- 84"
Worksurface depths	24" - 30"
Max lifting capacity	260 lbs
Base weight without top	66 lbs
Gauge of Steel	Inner/Middle tubes:1.5mm/Outer tube 1.5mm
Speed	36mm/s
Table Not in Motion,Electrical Draw	.3 W
Loaded Running Table,Electrical Draw	400W
Decibel Rating	50 db
Power Cord	10' cord - 3 PRONG PLUG
Finishes	CW, BU, SV
UL	UL962
Warranty	5 YEARS

Technical Specifications for Bases - 2 stage

Corner Legs

See page 40

Display	Digital display with four programmable presets
Foot Options	24"
Legs	T LEG
Leg Post Size	2.72" x 2.72"
Height range(excluding top)	27"- 45.5"
Frame width expansion	L: 55.5"- 79" / R:55.5"- 79"
Worksurface widths	58" - 84"
Worksurface depths	24" - 30"
Max lifting capacity	330 lbs
Base weight without top	85lbs
Gauge of Steel	Inner/Middle tubes:1.5mm/Outer tube 1.5mm
Speed	36mm/s
Table Not in Motion,Electrical Draw	.3 W
Loaded Running Table,Electrical Draw	400W
Decibel Rating	50 db
Power Cord	10' cord - 3 PRONG PLUG
Finishes	CW, BU, SV
UL	UL962
Warranty	5 years

SPECIFY 3 STAGE

Straight T-Leg Base

3 stage

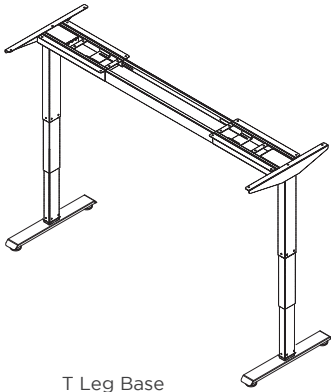

T Leg Base

DESCRIPTION

Electric height 3 stage adjustable base range 24.5"-50"

NOTES

- Order worksurface separately
- Base adjusts 38" to 68" wide
- Maximum recommended top: 84"
- Minimum recommended top: 40"
- Weight load 220 lbs
- Fixed trough cover - see page 23
- Maximum recommended overhang of 12"

SPECIFICATION OPTIONS

product #: see charts below
base finish: page 9

ORDER EXAMPLE

product #: FSQAHBT-24-3
base finish: SV Silver

STRAIGHT BASE

PART #	HEIGHT	WIDTH	DEPTH	PRICE	RECOMMENDED APPLICATION
FSQAHBT-24-3	24.5" - 50"	40"-78"	24"	\$1,675	<ul style="list-style-type: none"> • Order 24" base for use with 30" deep worksurfaces • Order 30" base for use with 36" deep worksurfaces • Minimum worksurface width: 40" • Maximum recommended worksurface width: 84" • 120° corners - use straight base on 36" and 42" wide worksurfaces • 90° corners, equal or extended - use corner base, page 24 (exception: 90° 48" top uses straight base, see images)
FSQAHBT-30-3	24.5" - 50"	40"-78"	30"	\$1,675	

Straight C-Leg Base

3 stage

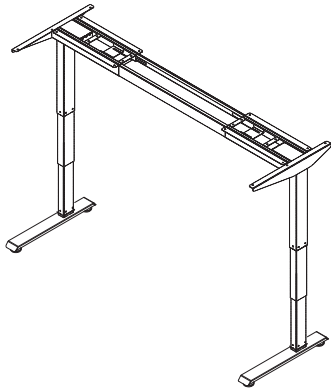

C-Leg Base

DESCRIPTION

Electric height 3 stage adjustable base range 24.5"-50"

NOTES

- Order worksurface separately
- Base adjusts 38" to 68" wide
- Maximum recommended top: 84"
- Minimum recommended top: 40"
- Weight load 220 lbs
- Fixed trough cover - see page 23
- Maximum recommended overhang of 12"

SPECIFICATION OPTIONS

product #: see charts below
base finish: page 9

ORDER EXAMPLE

product #: FSQAHBC-24-3
base finish: CW Cloud White

STRAIGHT BASE

PART #	HEIGHT	WIDTH	DEPTH	PRICE	RECOMMENDED APPLICATION
FSQAHBC-24-3	24.5" - 50"	40"-78"	24"	\$1,675	<ul style="list-style-type: none"> • Order 24" base for use with 30" deep worksurfaces • Order 30" base for use with 36" deep worksurfaces • Minimum worksurface width: 40" • Maximum recommended worksurface width: 84" • 120° corners - use straight base on 36" and 42" wide worksurfaces • 90° corners, equal or extended - use corner base, page 24 (exception: 90° 48" top uses straight base, see images)
FSQAHBC-30-3	24.5" - 50"	40"-78"	30"	\$1,675	

Corner T-Leg Base

3 stage

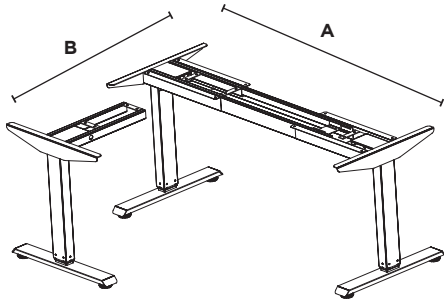

T Leg Base

DESCRIPTION

Electric height 3 stage adjustable base range 24.5"-50"

NOTES

- Includes (3) T-Leg bases at the ends and middle of the worksurface
- Order worksurface separately
- Base is: **B** - 36"-54"
A - 38"-68"
- Maximum recommended top: 72x96" or 84x84"
- Minimum recommended top: 36x40"
- Weight load 331 lbs
- Fixed trough cover - see page 23
- Maximum recommended overhang of 12"

SPECIFICATION OPTIONS

product #: see charts below
base finish: page 9

ORDER EXAMPLE

product #: FCNAHBT-24-3
base finish: CW Cloud White

CORNER BASE

PART #	HEIGHT	WIDTH	DEPTH	PRICE	RECOMMENDED APPLICATION
FCNAHBT-24-3	24.5" - 50"	40"-78"	24"	\$2,300	<ul style="list-style-type: none"> • Order 24" base for use with 30" deep worksurfaces • Order 30" base for use with 36" deep worksurfaces • 120° corners - use corner base on 48" wide worksurfaces • 90° corners - use corner base on 42" corner worksurfaces and all size extended corner worksurfaces • My-Hite bases are not for use with 36"x36" 90° corner worksurfaces • See page 24 for details
FCNAHBT-30-3	24.5" - 50"	40"-78"	30"	\$2,300	

Corner C-Leg Base

3 stage

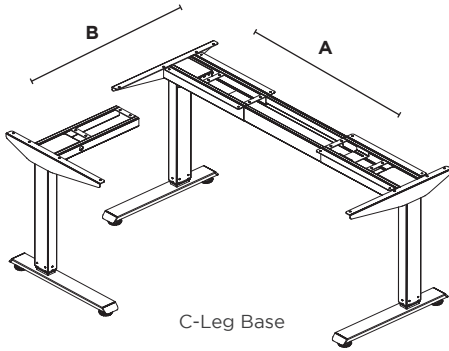

DESCRIPTION

Electric height 3 stage adjustable base range 24.5"-50"

NOTES

- Includes (3) C-Leg bases at the ends and middle of the worksurface
- Order worksurface separately
- Base is: **B** - 36"-54"
A - 38"-68"
- Maximum recommended top: 72x96" or 84x84"
- Minimum recommended top: 36x40"
- Weight load 331 lbs
- Fixed trough cover - see page 23
- Maximum recommended overhang of 12"

SPECIFICATION OPTIONS

product #: see charts below
base finish: page 9

ORDER EXAMPLE

product #: FCNAHBC-24-3
base finish: CW Cloud White

CORNER BASE

PART #	HEIGHT	WIDTH	DEPTH	PRICE	RECOMMENDED APPLICATION
FCNAHBC-24-3	24.5" - 50"	40"-78"	24"	\$2,300	<ul style="list-style-type: none"> • Order 24" base for use with 30" deep worksurfaces • Order 30" base for use with 36" deep worksurfaces • 120° corners - use corner base on 48" wide worksurfaces • 90° corners - use corner base on 42" corner worksurfaces and all size extended corner worksurfaces • My-Hite bases are not for use with 36"x36" 90° corner worksurfaces • See page 24 for details
FCNAHBC-30-3	24.5" - 50"	40"-78"	30"	\$2,300	

Corner T-Leg Post Base

3 stage

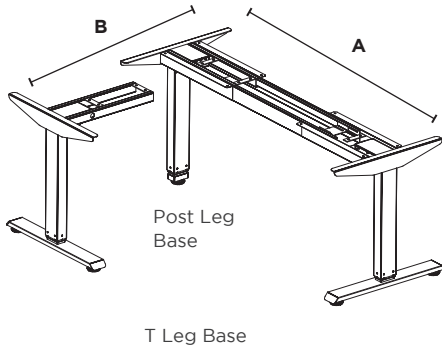

DESCRIPTION

Electric height 3 stage adjustable base range 24.5"-50"

NOTES

- Includes (2) T-Leg bases at the ends and (1) Post Leg in the center
- Order worksurface separately
- Base is: **B** - 36"-54"
A - 38"-68"
- Maximum recommended top: 72x96" or 84x84"
- Minimum recommended top: 36x40"
- Weight load 331 lbs
- Fixed trough cover - see page 23
- Maximum recommended overhang of 12"

SPECIFICATION OPTIONS

product #: see charts below
base finish: page 9

ORDER EXAMPLE

product #: FCNPAHBT-24-3
base finish: CW Cloud White

CORNER BASE

PART #	HEIGHT	WIDTH	DEPTH	PRICE
FCNPAHBT-24-3	24.5" - 50"	40"-78"	24"	\$2,300
FCNPAHBT-30-3	24.5" - 50"	40"-78"	30"	\$2,300

RECOMMENDED APPLICATION

- Order 24" base for use with 30" deep worksurfaces
- Order 30" base for use with 36" deep worksurfaces
- 120° corners - use corner base on 48" wide worksurfaces
- 90° corners - use corner base on 42" corner worksurfaces and all size extended corner worksurfaces
- My-Hite bases are not for use with 36"x36" 90° corner worksurfaces
- See page 24 for details

Corner C-Leg Post Base

3 stage

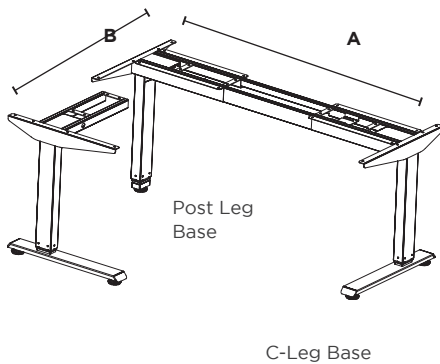

DESCRIPTION

Electric height 3 stage adjustable base range 24.5"-50"

NOTES

- Includes (2) C-Leg bases at the ends and (1) Post Leg in the center
- Order worksurface separately
- Base is: **B** - 36"-54"
A - 38"-68"
- Maximum recommended top: 72x96" or 84x84"
- Minimum recommended top: 36x40"
- Weight load 331 lbs
- Fixed trough cover - see page 23
- Maximum recommended overhang of 12"

SPECIFICATION OPTIONS

product #: see charts below
base finish: see page X

ORDER EXAMPLE

product #: FCNPAHB-24-3
base finish: CW Cloud White

CORNER BASE

PART #	HEIGHT	WIDTH	DEPTH	PRICE
FCNPAHBC-24-3	24.5" - 50"	40"-78"	24"	\$2,300
FCNPAHBC-30-3	24.5" - 50"	40"-78"	30"	\$2,300

RECOMMENDED APPLICATION

- Order 24" base for use with 30" deep worksurfaces
- Order 30" base for use with 36" deep worksurfaces
- 120° corners - use corner base on 48" wide worksurfaces
- 90° corners - use corner base on 42" corner worksurfaces and all size extended corner worksurfaces
- My-Hite bases are not for use with 36"x36" 90° corner worksurfaces
- See page 24 for details

SPECIFY 2 STAGE

Straight T-Leg Base

2 stage

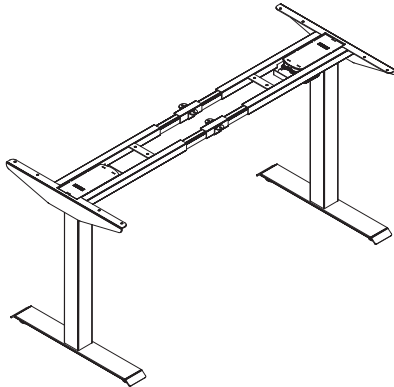

DESCRIPTION

Electric 2-stage height adjustable base range 28"- 45"

NOTES

- Order worksurface separately
- Base adjusts 41" to 74" wide
- Maximum recommended top: 84"
- Minimum recommended top: 42"
- Weight load - 260 lbs
- Maximum recommended overhang of 12"

SPECIFICATION OPTIONS

product #: see below
base finish: page 9

ORDER EXAMPLE

product #: FSQAHBT-24-2
base finish: SV Silver

STRAIGHT BASE

PART #	HEIGHT	WIDTH	DEPTH	PRICE	RECOMMENDED APPLICATION
FSQAHBT-24-2	28"- 45"	41"-74"	24"	\$1,167	<ul style="list-style-type: none"> • Supports 24" to 30" deep tops • For use with rectangular worksurfaces, certain sizes of 120° corners or 90° corners • See recommended top application on pg 28

Corner T-Leg Base

2 stage

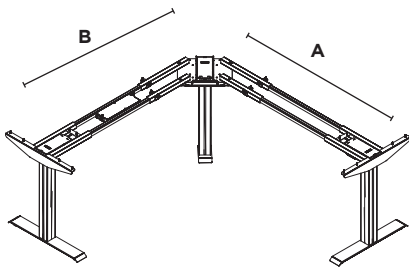

DESCRIPTION

Electric 2-stage height adjustable base range 28"- 45"

NOTES

- Order Worksurface separately
- Base is:
A - 55.5" to 79"
B - 55.5" to 79"
- Maximum recommended top: 84"x84" or 72"x96"
- Minimum recommended top: 58"x58"
- See page 10 for recommended base applications
- Weight load 330 lbs
- Maximum recommended overhang of 12"

SPECIFICATION OPTIONS

product #: see below
base finish: page 9

ORDER EXAMPLE

product #: FCNAHBT-24-2
base finish: SV Silver

CORNER BASE

PART #	HEIGHT	WIDTH	DEPTH	PRICE	RECOMMENDED APPLICATION
FCNAHBT-24-2	28"- 45"	41"-74"	24"	\$1,719	<ul style="list-style-type: none"> • For use with two piece curved corner or two piece rectangular worksurfaces • See recommended top application on pg 28

WORKSURFACES FOR FREESTANDING APPLICATION

Rectangular Freestanding Application

MY-HITE WORKSURFACES - FREESTANDING APPLICATION

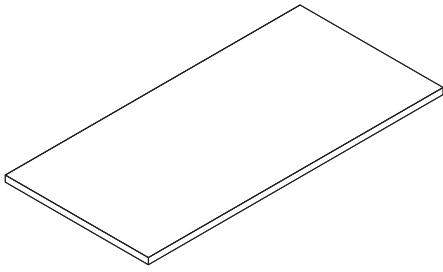

DESCRIPTION

Laminate worksurface with 3mm PVC edge

NOTES

- Tops are intended for freestanding application
- See system pricebook for use inside a paneled workstation
- Add grommet cutout (add \$75 list). Specify grommet placement GL, GC, GR

SPECIFICATION OPTIONS

product #: see charts below
edge finish: see page 9
worksurface finish: see page 9

ORDER EXAMPLE

product #: FSQAHT.3054
edge finish: DT Dark Tone, E12
worksurface finish: Light Maple, M1
grommet location: GL
grommet color: Cloud White

RECTANGULAR WORKSURFACE

PART #	WIDTH	DEPTH	LIST
FSQAHT.2442	42"	24"	\$247
FSQAHT.2448	48"	24"	\$252
FSQAHT.2454	54"	24"	\$289
FSQAHT.2460	60"	24"	\$315
FSQAHT.2466	66"	24"	\$351
FSQAHT.2472	72"	24"	\$360
FSQAHT.2478	78"	24"	\$444
FSQAHT.2484	84"	24"	\$544

NOTES

- Sizes are actual . for example: FSQAHT.2448 is 23 7/8" x 47 7/8"
- Not recommended in paneled workstation applications
- Topsize not reduced to eliminate pinch points

FSQAHT.3042	42"	30"	\$317
FSQAHT.3048	48"	30"	\$325
FSQAHT.3054	54"	30"	\$368
FSQAHT.3060	60"	30"	\$394
FSQAHT.3066	66"	30"	\$440
FSQAHT.3072	72"	30"	\$449
FSQAHT.3078	78"	30"	\$552
FSQAHT.3084	84"	30"	\$652

FSQAHT.3642	42"	36"	\$382
FSQAHT.3648	48"	36"	\$389
FSQAHT.3654	54"	36"	\$681
FSQAHT.3660	60"	36"	\$689
FSQAHT.3666	66"	36"	\$696
FSQAHT.3672	72"	36"	\$704
FSQAHT.3678	78"	36"	\$711
FSQAHT.3684	84"	36"	\$811

Corner Freestanding Application

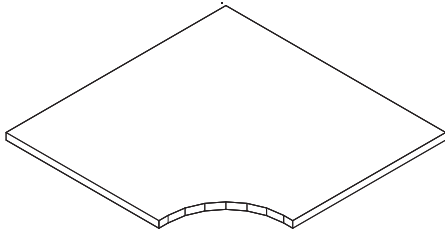

DESCRIPTION

Laminate worksurface with 3mm PVC edge

NOTES

- Tops are intended for freestanding application
- See System pricebook for use inside a paneled workstation
- Add grommet cutout (add \$75 list). Specify grommet placement GL or GR

SPECIFICATION OPTIONS

product #: see charts below
edge finish: see page 9
worksurface finish: see page 9

ORDER EXAMPLE

product #: FCCAHS.2448
edge finish: DT Dark Tone, E12
worksurface finish: Light Maple, M1
grommet location: GL
grommet color: Cloud White

CORNER WORKSURFACE

PART #	WIDTH	DEPTH	LIST
FCCAHS.2442	42"	24"	\$364
FCCAHS.2448	48"	24"	\$384
FCCAHS.3042	42"	30"	\$395
FCCAHS.3048	48"	30"	\$416

NOTES

- Sizes are actual . for example: FCCAHS.2448 is 23 7/8" x 47 7/8"
- Not recommended in paneled workstation applications
- Topsize not reduced to eliminate pinch points

90° Extended Curved Corner Freestanding Application

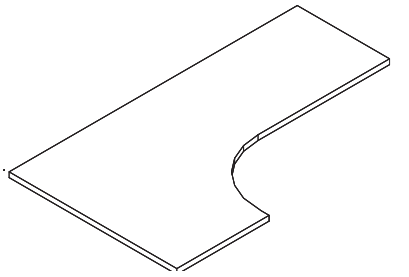

Right Extended shown

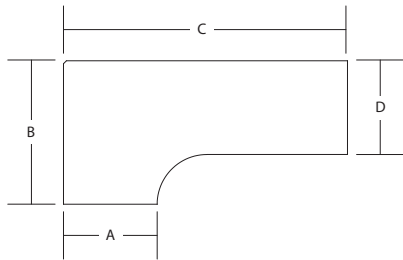

DESCRIPTION

Laminate worksurface with 3mm PVC edge

NOTES

- Tops are intended for freestanding application
- See system pricebook for use inside a paneled workstation
- Add grommet cutout (add \$75 list). Specify grommet placement GL, GC, GR

SPECIFICATION OPTIONS

product #: see charts below
edge finish: see page 9
worksurface finish: see page 9
left or right extended: L for Left, R for Right

ORDER EXAMPLE

product #: FCCAHS.24366024L
edge finish: E10 Espresso
worksurface finish: M11 Light Walnut
grommet location: PG5L-C
grommet color: Cloud White

**24" D CONNECTING SIDE
 24" D EXTENSION
 36" D**

PART #	HEIGHT	A	B	C	D	WT. (LBS)	PRICE
FCCAHS.24366024L	1.25"	24"	36"	60"	24"	76	\$475
FCCAHS.24366024R	1.25"	24"	36"	60"	24"	76	\$475
FCCAHS.24366624L	1.25"	24"	36"	66"	24"	76	\$529
FCCAHS.24366624R	1.25"	24"	36"	66"	24"	76	\$529
FCCAHS.24367224L	1.25"	24"	36"	72"	24"	82	\$538
FCCAHS.24367224R	1.25"	24"	36"	72"	24"	82	\$538
FCCAHS.24367824L	1.25"	24"	36"	78"	24"	82	\$645
FCCAHS.24367824R	1.25"	24"	36"	78"	24"	82	\$645
FCCAHS.24368424L	1.25"	24	36"	84	24	104	\$774
FCCAHS.24368424R	1.25"	24	36"	84	24	104	\$774

**30" D CONNECTING SIDE
 30" D EXTENSION
 36" D**

PART #	HEIGHT	A	B	C	D	WT. (LBS)	PRICE
FCCAHS.30366030L	1.25"	30"	36"	60"	30"	87	\$520
FCCAHS.30366030R	1.25"	30"	36"	60"	30"	87	\$520
FCCAHS.30366630L	1.25"	30"	36"	66"	30"	87	\$573
FCCAHS.30366630R	1.25"	30"	36"	66"	30"	87	\$573
FCCAHS.30367230L	1.25"	30"	36"	72"	30"	95	\$582
FCCAHS.30367230R	1.25"	30"	36"	72"	30"	95	\$582
FCCAHS.30367830L	1.25"	30"	36"	78"	30"	95	\$689
FCCAHS.30367830R	1.25"	30"	36"	78"	30"	95	\$689
FCCAHS.30368430L	1.25"	30"	36"	84	30"	112	\$826
FCCAHS.30368430R	1.25"	30"	36"	84	30"	112	\$826

**24" D CONNECTING SIDE
24" D EXTENSION
42" D**

PART #	HEIGHT	A	B	C	D	WT. (LBS)	PRICE
FCCAHS.24426024L	1.25"	24"	42"	60"	24"	83	\$571
FCCAHS.24426024R	1.25"	24"	42"	60"	24"	83	\$571
FCCAHS.24426624L	1.25"	24"	42"	66"	24"	83	\$643
FCCAHS.24426624R	1.25"	24"	42"	66"	24"	83	\$643
FCCAHS.24427224L	1.25"	24"	42"	72"	24"	89	\$652
FCCAHS.24427224R	1.25"	24"	42"	72"	24"	89	\$652
FCCAHS.24427824L	1.25"	24"	42"	78"	24"	89	\$791
FCCAHS.24427824R	1.25"	24"	42"	78"	24"	89	\$791
FCCAHS.24428424L	1.25"	24	42"	84	24	104	\$949
FCCAHS.24428424R	1.25"	24	42"	84	24	104	\$949

**30" D CONNECTING SIDE
30" D EXTENSION
42" D**

PART #	HEIGHT	A	B	C	D	WT. (LBS)	PRICE
FCCAHS.30426030L	1.25"	30"	42"	60"	30"	95	\$615
FCCAHS.30426030R	1.25"	30"	42"	60"	30"	95	\$615
FCCAHS.30426630L	1.25"	30"	42"	66"	30"	95	\$687
FCCAHS.30426630R	1.25"	30"	42"	66"	30"	95	\$687
FCCAHS.30427230L	1.25"	30"	42"	72"	30"	103	\$696
FCCAHS.30427230R	1.25"	30"	42"	72"	30"	103	\$696
FCCAHS.30427830L	1.25"	30"	42"	78"	30"	103	\$835
FCCAHS.30427830R	1.25"	30"	42"	78"	30"	103	\$835
FCCAHS.30428430L	1.25"	30"	42"	84	30"	112	\$1002
FCCAHS.30428430R	1.25"	30"	42"	84	30"	112	\$1002

**24" D CONNECTING SIDE
24" D EXTENSION
48" D**

PART #	HEIGHT	A	B	C	D	WT. (LBS)	PRICE
FCCAHS.24486024L	1.25"	24"	48"	60"	24"	89	\$580
FCCAHS.24486024R	1.25"	24"	48"	60"	24"	89	\$580
FCCAHS.24486624L	1.25"	24"	48"	66"	24"	89	\$652
FCCAHS.24486624R	1.25"	24"	48"	66"	24"	89	\$652
FCCAHS.24487224L	1.25"	24"	48"	72"	24"	95	\$667
FCCAHS.24487224R	1.25"	24"	48"	72"	24"	95	\$667
FCCAHS.24487824L	1.25"	24"	48"	78"	24"	95	\$813
FCCAHS.24487824R	1.25"	24"	48"	78"	24"	95	\$813
FCCAHS.24488424L	1.25"	24	48"	84	24	112	\$975
FCCAHS.24488424R	1.25"	24	48"	84	24	112	\$975

**30" D CONNECTING SIDE
30" D EXTENSION
48" D**

MY-HITE WORKSURFACES - FREESTANDING APPLICATION

PART #	HEIGHT	A	B	C	D	WT. (LBS)	PRICE
FCCAHS.30486030L	1.25"	30"	48"	60"	30"	104	\$625
FCCAHS.30486030R	1.25"	30"	48"	60"	30"	104	\$625
FCCAHS.30486630L	1.25"	30"	48"	66"	30"	104	\$696
FCCAHS.30486630R	1.25"	30"	48"	66"	30"	104	\$696
FCCAHS.30487230L	1.25"	30"	48"	72"	30"	112	\$712
FCCAHS.30487230R	1.25"	30"	48"	72"	30"	112	\$712
FCCAHS.30487830L	1.25"	30"	48"	78"	30"	112	\$857
FCCAHS.30487830R	1.25"	30"	48"	78"	30"	112	\$857
FCCAHS.30488430L	1.25"	30"	48"	84	30"	112	\$1028
FCCAHS.30488430R	1.25"	30"	48"	84	30"	112	\$1028

Rectangular Extension Freestanding Application

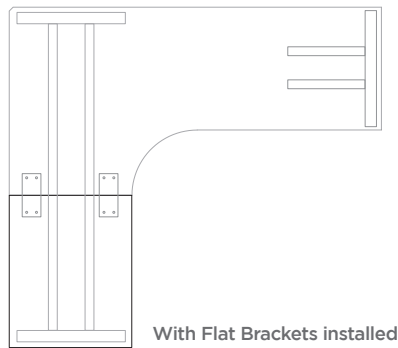

DESCRIPTION

Laminate worksurface with 3mm PVC edge

NOTES

- For use in combination with Extended Corner Worksurfaces and Corner My-Hite Bases only
- Not for use alone, nor with straight bases
- Maximum width combined: 72x96" or 84x84"

SPECIFICATION OPTIONS

product #: see charts below
worksurface finish: see page 9
edge finish: see page 9

ORDER EXAMPLE

product #: FSQAHT.2424
worksurface finish: Light Maple, M1
edge finish: DT Dark Tone, E12

STANDARD GRAIN

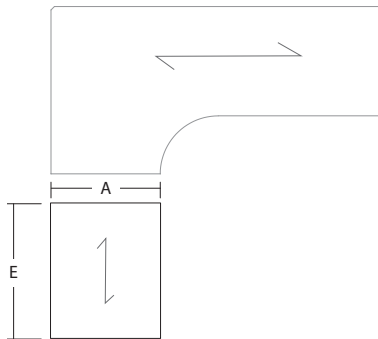

PART #	DEPTH "A"	WIDTH "E"	LIST	NOTES
FSQAHT.2424	24"	24"	\$169	<ul style="list-style-type: none"> • Sizes are actual . for example: FSQAHT.2424 is 23 7/8" x 23 7/8" • Not recommended in paneled workstation applications • Topsize not reduced to eliminate pinch points • Standard default grain direction is left to right (See left)
FSQAHT.2430	24"	30"	\$194	
FSQAHT.2436	24"	36"	\$200	
FSQAHT.2442	24"	42"	\$247	
FSQAHT.2448	24"	48"	\$252	
FSQAHT.2454	24"	54"	\$289	
FSQAHT.2460	24"	60"	\$315	
FSQAHT.3024	30"	24"	\$225	
FSQAHT.3030	30"	30"	\$257	
FSQAHT.3036	30"	36"	\$263	
FSQAHT.3042	30"	42"	\$317	
FSQAHT.3048	30"	48"	\$325	
FSQAHT.3054	30"	54"	\$368	
FSQAHT.3060	30"	60"	\$394	

CROSS GRAIN

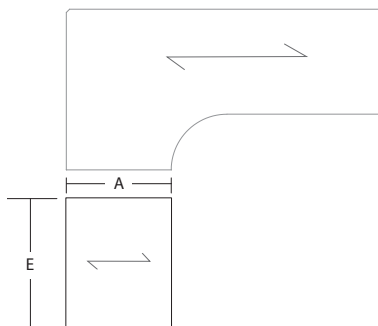

PART #	DEPTH "A"	WIDTH "E"	LIST	NOTES
FSQAHT.2430-CG	24"	30"	\$233	<ul style="list-style-type: none"> • Sizes are actual . for example: FSQAHT.2424 is 23 7/8" x 23 7/8" • Not recommended in paneled workstation applications • Topsize not reduced to eliminate pinch points • Cross grain direction is front to back (See left)
FSQAHT.2436-CG	24"	36"	\$240	
FSQAHT.2442-CG	24"	42"	\$296	
FSQAHT.2448-CG	24"	48"	\$302	
FSQAHT.2454-CG	24"	54"	\$347	
FSQAHT.2460-CG	24"	60"	\$378	
FSQAHT.3024-CG	30"	24"	\$270	
FSQAHT.3036-CG	30"	36"	\$316	
FSQAHT.3042-CG	30"	42"	\$380	
FSQAHT.3048-CG	30"	48"	\$390	
FSQAHT.3054-CG	30"	54"	\$442	
FSQAHT.3060-CG	30"	60"	\$473	

FLAT BRACKET

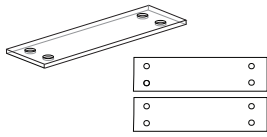

PART #	WIDTH	DEPTH	LIST	NOTES
FVFB.08	8"	2"	\$30	<ul style="list-style-type: none"> Used to unite two worksurfaces supported by one base. See page 40. Use a Flat Bracket pair to attach an Extended Curved Corner with a Rectangular Extension. Sold in pairs Black finish

ANTI-SAG BARS



PART #	WIDTH	LIST	NOTES
FWASB.42	42"	\$95	<ul style="list-style-type: none"> Anti-Sag bar, 42" wide with (8) screws. For use with 48 & 54" worktops
FWASB.54	54"	\$121	<ul style="list-style-type: none"> Anti-Sag bar, 54" wide with (10) screws. For use with 60 & 66" worktops
FWASB.66	66"	\$146	<ul style="list-style-type: none"> Anti-Sag bar, 66" wide with (12) screws. For use with 72 & 78" worktops

D-Shaped Freestanding Application

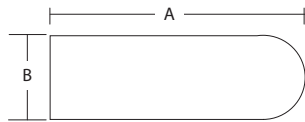
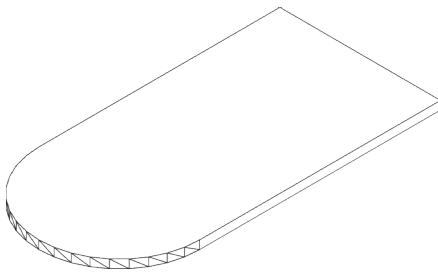

DESCRIPTION

Laminate worksurface with 3mm PVC edge

NOTES

- Tops are intended for freestanding application
- See system pricebook for use inside a paneled workstation
- Add grommet cutout (add \$75 list). Specify grommet placement GC

SPECIFICATION OPTIONS

product #: see charts below
edge finish: see page 9
worksurface finish: see page 9

ORDER EXAMPLE

product #: FDAHT.2448
edge finish: E10 Espresso
worksurface finish: M11 Light Walnut
grommet location: GC
grommet color: Cloud White

D-SHAPED

PART #	HEIGHT	A	B	C	D	PRICE
FDAHT.2448	1.25"	48"	24"	—	—	\$369
FDAHT.2460	1.25"	60"	24"	—	—	\$413
FDAHT.3048	1.25"	48"	30"	—	—	\$405
FDAHT.3060	1.25"	60"	30"	—	—	\$448
FDAHT.3072	1.25"	72"	30"	—	—	\$491
FDAHT.3672	1.25"	72"	36"	—	—	\$542

NOTES

- Sizes are actual - for example: FDAHT.2448 is 23 7/8" x 47 7/8"
- Not recommended in paneled workstation applications
- Topsize not reduced to eliminate pinch points

Wedge Freestanding Application

MY-HITE WORKSURFACES - FREESTANDING APPLICATION

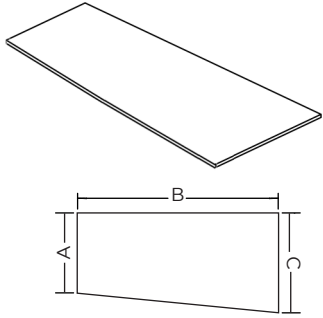

DESCRIPTION

Laminate worksurface with 3mm PVC edge

NOTES

- Tops are intended for freestanding application
- See system pricebook for use inside a paneled workstation
- Add grommet cutout (add \$75 list). Specify grommet placement GL, GC, GR

SPECIFICATION OPTIONS

product #: see charts below
edge finish: see page 9
worksurface finish: see page 9

ORDER EXAMPLE

product #: FWDAHT.244230
edge finish: E10 Espresso
worksurface finish: M11 Light Walnut
grommet location: PG5L-C
grommet color: Cloud White

**24"D LEFT
30"D RIGHT**

PART #	HEIGHT	A	B	C	D	PRICE	NOTES
FWDAHT.244230	1.25"	24"	42"	30"	—	\$328	<ul style="list-style-type: none"> • Sizes are actual - for example; FWDAHT-244230 is 23 7/8" x 41 7/8" x 29 7/8" • Not recommended in paneled workstation applications • Topsize not reduced to eliminate pinch points
FWDAHT.244830	1.25"	24"	48"	30"	—	\$335	
FWDAHT.245430	1.25"	24"	54"	30"	—	\$380	
FWDAHT.246030	1.25"	24"	60"	30"	—	\$407	
FWDAHT.246630	1.25"	24"	66"	30"	—	\$454	
FWDAHT.247230	1.25"	24"	72"	30"	—	\$464	
FWDAHT.247830	1.25"	24"	78"	30"	—	\$540	

**30"D LEFT
24"D RIGHT**

PART #	HEIGHT	A	B	C	D	PRICE
FWDAHT.304224	1.25"	30"	42"	24"	—	\$328
FWDAHT.304824	1.25"	30"	48"	24"	—	\$335
FWDAHT.305424	1.25"	30"	54"	24"	—	\$380
FWDAHT.306024	1.25"	30"	60"	24"	—	\$407
FWDAHT.306624	1.25"	30"	66"	24"	—	\$454
FWDAHT.307224	1.25"	30"	72"	24"	—	\$464
FWDAHT.307824	1.25"	30"	78"	24"	—	\$540

120° Corner / 90° Ends Freestanding Application

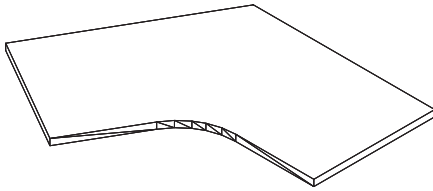

DESCRIPTION

Laminate worksurface with 3mm PVC edge

NOTES

- Tops are intended for freestanding application
- See system pricebook for use inside a paneled workstation
- Add grommet cutout ((add \$75 list).) Specify grommet placement GL, GC, GR

SPECIFICATION OPTIONS

product #: see charts below
top, edge finish: see page 9
worksurface finish: see page 9

ORDER EXAMPLE

product #: F120AHT-90WS.2436
top, edge finish: E10 Espresso
worksurface finish: M11 Light Walnut
grommet location: GL
grommet color: Cloud White

120° CORNER 90° ENDS

PART #	HEIGHT	A	B	C	D	PRICE
F120AHT-90WS.2436	1.25"	24"	36"	—	—	\$565
F120AHT-90WS.2442	1.25"	24"	42"	—	—	\$676
F120AHT-90WS.2448	1.25"	24"	48"	—	—	\$822

NOTES

- Sizes are actual - for example: F120AHT-90WS.2436 is 23 7/8" x 35 7/8"
- Not recommended in paneled workstation applications
- Topsize not reduced to eliminate pinch points

120° Corner / 120° Ends Freestanding Application

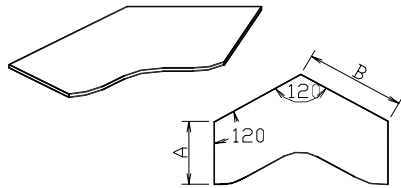

DESCRIPTION

Laminate worksurface with 3mm PVC edge

NOTES

- Tops are intended for freestanding application
- See system pricebook for use inside a paneled workstation
- Add grommet cutout (add \$75 list). Specify grommet placement GL, GC, GR

SPECIFICATION OPTIONS

product #: see charts below
edge finish: see page 9
worksurface finish: see page 9

ORDER EXAMPLE

product #: F120AHT-120WS.2436
edge finish: E10 Espresso
worksurface finish: M11 Light Walnut
grommet location: PG5L-C
grommet color: Cloud White

120° CORNER 120° ENDS

PART #	HEIGHT	A	B	C	D	PRICE
F120AHT-120WS.2436	1.25"	24"	36"	—	—	\$571
F120AHT-120WS.2442	1.25"	24"	42"	—	—	\$684
F120AHT-120WS.2448	1.25"	24"	48"	—	—	\$831

NOTES

- Sizes are actual - for example: „ F120AHT-120WS.2436 is 23 7/8” x 35 7/8”
- Not recommended in paneled workstation applications
- Topsize not reduced to eliminate pinch points

Modesty Panel, Laminate

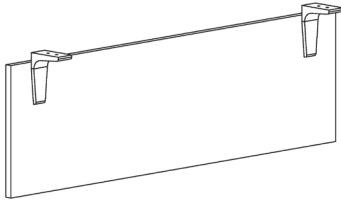

DESCRIPTION

Laminate modesty panel with matching 2mm PVC edge

NOTES

- Actual modesty is shorter than the worktop to clear the My-Hite base.
- Example: FAHLMOD.1648 for use on 46"/48" width table, actual width is 40"

SPECIFICATION OPTIONS

product #: see charts below
Paint (Brackets) CW, BU, SV
Laminate (Modesty Panel) see page 9

ORDER EXAMPLE

product #: FAHLMOD.0860
paint: CW, Cloud White
laminate: M12, Medium Walnut

Laminate Modesty Panel

PART #	HEIGHT	WIDTH	LIST
FAHLMOD.0842	8"	34"	\$180
FAHLMOD.0848	8"	40"	\$185
FAHLMOD.0854	8"	46"	\$191
FAHLMOD.0860	8"	52"	\$283
FAHLMOD.0866	8"	58"	\$289
FAHLMOD.0872	8"	64"	\$295
FAHLMOD.0878	8"	70"	\$300

NOTES

- Modesty panel will be shorter than top to clear the My-Hite base.

Example:

1. FSQAHT-2460 order FAHLMOD.1660 (actual width 52")
2. FIRWS.2370 (Interra pricebook) order FAHLMOD.1672 (actual width 64")

FAHLMOD.1642	16"	34"	\$221
FAHLMOD.1648	16"	40"	\$227
FAHLMOD.1654	16"	46"	\$233
FAHLMOD.1660	16"	52"	\$359
FAHLMOD.1666	16"	58"	\$364
FAHLMOD.1672	16"	64"	\$370
FAHLMOD.1678	16"	70"	\$376

Privacy Screen, Fabric

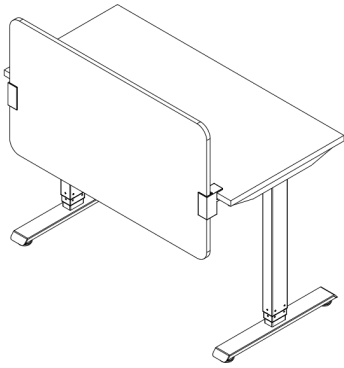

DESCRIPTION

Work Surface mounted fabric covered privacy screen

NOTES

- Fabric screen is non-tackable
- To use a wire manager on your My-Hite table with a fabric covered privacy screen, you must order "with gap".
- Actual screen is shorter than the worktop.
- Example: FPSFLUSH.2448 for use on 46"/48" width table, actual width of screen is 40".
- **Passage and Terrain fabric not approved for this application**

SPECIFICATION OPTIONS

product #: see charts below
Paint (Brackets): CW, BU, SV
fabric: see page 7 (Passage and Terrain fabric not approved for this application)

ORDER EXAMPLE

product #: FPSFLUSH.2448
brackets: SV, Silver
fabric: PF-101-2 Slide, Slate

Fabric Privacy Screen - Flush

Have grommet? Go flush

PART #	HEIGHT	WIDTH	LIST
FPSFLUSH.2442	24"	34"	\$480
FPSFLUSH.2448	24"	40"	\$520
FPSFLUSH.2454	24"	46"	\$560
FPSFLUSH.2460	24"	52"	\$601
FPSFLUSH.2466	24"	58"	\$642
FPSFLUSH.2472	24"	64"	\$683

NOTES

- Privacy screen sits flush with the back of the worktop.
- Privacy screen is 8" shorter than free standing top width and 6" shorter than a worksurface from a paneled system.
- Example:
- FSQAHT-2460 order FPSFLUSH.2460 (actual width 52")

Fabric Privacy Screen - with Wire Management Gap

Need space between the screen and top? Add gap

PART #	HEIGHT	WIDTH	LIST
FPSGAP.2442	24"	34"	\$480
FPSGAP.2448	24"	40"	\$520
FPSGAP.2454	24"	46"	\$560
FPSGAP.2460	24"	52"	\$601
FPSGAP.2466	24"	58"	\$642
FPSGAP.2472	24"	64"	\$683

NOTES

- With 1" gap at back of worksurface for cord/wire management.
- Example:
 1. FSQAHT-2460 order FPSGAP.2460 (actual width 52")
- Privacy screen sits flush with the back of the worktop.
- Privacy screen is 8" shorter than free standing top width and 6" shorter than a worksurface from a paneled system.
- Example:
 1. FSQAHT-2460 order FPSGAP.2460 (actual width 52")

Privacy Screen, Marker Board

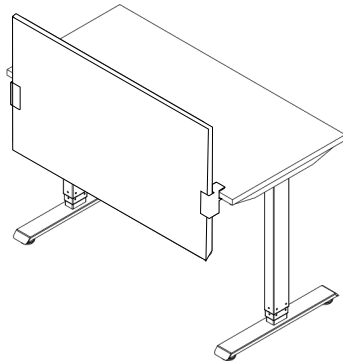

DESCRIPTION

Work Surface mounted marker board privacy screen

NOTES

- To use a wire manager on your My-Hite table with a marker board privacy screen, you must order "with gap".
- Actual screen is shorter than the worktop.
- Example: FMPSFLUSH.2448 for use on 46"/48" width table, actual width of screen is 40"

SPECIFICATION OPTIONS

product #: see charts below
Paint (Brackets): CW, BU, SV

ORDER EXAMPLE

product #: FMPSFLUSH.2448
brackets: SV, Silver

Marker Board Privacy Screen - Flush

Have grommet? Go flush

PART #	HEIGHT	WIDTH	LIST
FMPSFLUSH.2442	24"	34"	\$621
FMPSFLUSH.2448	24"	40"	\$711
FMPSFLUSH.2454	24"	46"	\$801
FMPSFLUSH.2460	24"	52"	\$892
FMPSFLUSH.2466	24"	58"	\$982
FMPSFLUSH.2472	24"	64"	\$1,073

NOTES

- Privacy screen sits flush with the back of the worktop.
- Privacy screen is 8" shorter than free standing top width and 6" shorter than a worksurface from a paneled system.

Example:

1. FSQAHT-2460 order FMPSFLUSH.2460 (actual width 52")

Marker Board Privacy Screen- with Wire Management Gap

Need space between the screen and top? Add gap

PART #	HEIGHT	WIDTH	LIST
FMPGAP.2442	24"	34"	\$621
FMPGAP.2448	24"	40"	\$711
FMPGAP.2454	24"	46"	\$801
FMPGAP.2460	24"	52"	\$892
FMPGAP.2466	24"	58"	\$982
FMPGAP.2472	24"	64"	\$1,073

NOTES

- With 1" gap at back of worksurface for cord/wire management.

Example:

1. FSQAHT-2460 order FMPGAP.2460 (actual width 52")
- Privacy screen sits flush with the back of the worktop.
 - Privacy screen is 8" shorter than free standing top width and 6" shorter than a worksurface from a paneled system.
- Example:
1. FSQAHT-2460 order FMPGAP.2460 (actual width 52")

Privacy Screen, Laminate

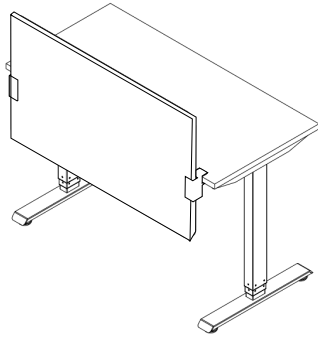

DESCRIPTION

Work Surface mounted laminate privacy screen

NOTES

- To use a wire manager on your My-Hite table with a laminate privacy screen, you must order "with gap".
- Actual screen is shorter than the worktop.

SPECIFICATION OPTIONS

product #: see charts below
Paint (Brackets): CW, BU, SV
finish: see page 9

ORDER EXAMPLE

product #: FPSFLUSH.2454
brackets: SV, Silver

Laminate Privacy Screen - Flush

Have grommet? Go flush

PART #	HEIGHT	WIDTH	LIST
FLPSFLUSH.2442	24"	34"	\$327
FLPSFLUSH.2448	24"	40"	\$364
FLPSFLUSH.2454	24"	46"	\$400
FLPSFLUSH.2460	24"	52"	\$436
FLPSFLUSH.2466	24"	58"	\$473
FLPSFLUSH.2472	24"	64"	\$509

NOTES

- Privacy screen sits flush with the back of the worktop.
- Privacy screen is 8" shorter than free standing top width and 6" shorter than a worksurface from a paneled system.

Example:

1. FSQAHT-2460 order FPSFLUSH.2460 (actual width 52")

Laminate Privacy Screen - with Wire Management Gap

Need space between the screen and top? Add gap

PART #	HEIGHT	WIDTH	LIST
FLPSGAP.2442	24"	34"	\$327
FLPSGAP.2448	24"	40"	\$364
FLPSGAP.2454	24"	46"	\$400
FLPSGAP.2460	24"	52"	\$436
FLPSGAP.2466	24"	58"	\$473
FLPSGAP.2472	24"	64"	\$509

NOTES

- With 1" gap at back of worksurface for cord/wire management.

Example:

1. FSQAHT-2460 order FPSGAP.2460 (actual width 52")

- Privacy screen sits flush with the back of the worktop.

- Privacy screen is 8" shorter than free standing top width and 6" shorter than a worksurface from a paneled system.

Example:

1. FSQAHT-2460 order FLPSGAP.2460 (actual width 52")

Worksurface Mounted Screens, Clear

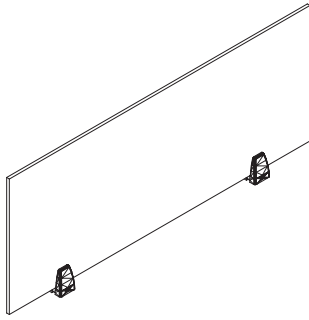

DESCRIPTION

Surface mounted glass screens, including hardware.

NOTES

- Includes: (2) supporting brackets for screens up to 48"W, (3) supporting brackets for screens 54"W and wider.
- Mounts to any laminate/veneer worksurface top.

SPECIFICATION OPTIONS

product #: see charts below
Paint (Brackets) CW, BU, SV

ORDER EXAMPLE

product #: FWSMG.0824-CL
paint: SV Silver

Glass Screens, Clear 8" HIGH

PART #	HEIGHT	WIDTH	LIST
FWSMG.0824-CL	8"	24"	\$145
FWSMG.0830-CL	8"	30"	\$157
FWSMG.0836-CL	8"	36"	\$169
FWSMG.0842-CL	8"	42"	\$181
FWSMG.0848-CL	8"	48"	\$193
FWSMG.0854-CL	8"	54"	\$253
FWSMG.0860-CL	8"	60"	\$265
FWSMG.0866-CL	8"	66"	\$277
FWSMG.0872-CL	8"	72"	\$288

NOTES

- Screen mounts to any laminate/veneer worksurface top

Glass Screens, Clear 14" HIGH

PART #	HEIGHT	WIDTH	LIST
FWSMG.1424-CL	14"	24"	\$182
FWSMG.1430-CL	14"	30"	\$202
FWSMG.1436-CL	14"	36"	\$221
FWSMG.1442-CL	14"	42"	\$240
FWSMG.1448-CL	14"	48"	\$261
FWSMG.1454-CL	14"	54"	\$330
FWSMG.1460-CL	14"	60"	\$348
FWSMG.1466-CL	14"	66"	\$366
FWSMG.1472-CL	14"	72"	\$384

NOTES

- Screen mounts to any laminate/veneer worksurface top

Glass Screens, Clear 15" HIGH

PART #	HEIGHT	WIDTH	LIST
FWSMG.1522-CL	15"	22"	\$249
FWSMG.1528-CL	15"	28"	\$265

Worksurface Mounted Screens, Frosted

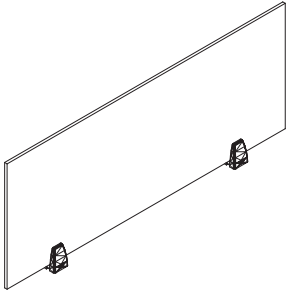

DESCRIPTION

Surface mounted glass screens, including hardware

SPECIFICATION OPTIONS

product #: see charts below
Paint (Brackets) CW, BU, SV

NOTES

- Includes: (2) supporting brackets for screens up to 48"W, (3) supporting brackets for screens 54"W and wider.
- Mounts to any laminate/veneer worksurface top.

ORDER EXAMPLE

product #: FWSMG.0824-FR
paint: SV Silver

Glass Screens, Frosted 8" HIGH

PART #	HEIGHT	WIDTH	LIST
FWSMG.0824-FR	8"	24"	\$203
FWSMG.0830-FR	8"	30"	\$230
FWSMG.0836-FR	8"	36"	\$257
FWSMG.0842-FR	8"	42"	\$285
FWSMG.0848-FR	8"	48"	\$312
FWSMG.0854-FR	8"	54"	\$364
FWSMG.0860-FR	8"	60"	\$374
FWSMG.0866-FR	8"	66"	\$384
FWSMG.0872-FR	8"	72"	\$394

NOTES

- Screen mounts to any laminate/veneer worksurface top

Glass Screens, Frosted 14" HIGH

PART #	HEIGHT	WIDTH	LIST
FWSMG.1424-FR	14"	24"	\$284
FWSMG.1430-FR	14"	30"	\$331
FWSMG.1436-FR	14"	36"	\$377
FWSMG.1442-FR	14"	42"	\$422
FWSMG.1448-FR	14"	48"	\$470
FWSMG.1454-FR	14"	54"	\$524
FWSMG.1460-FR	14"	60"	\$564
FWSMG.1466-FR	14"	66"	\$603
FWSMG.1472-FR	14"	72"	\$643

NOTES

- Screen mounts to any laminate/veneer worksurface top

Glass Screens, Frosted 15" HIGH

PART #	HEIGHT	WIDTH	LIST
FWSMG.1522-FR	15"	22"	\$346
FWSMG.1528-FR	15"	28"	\$387

Worksurface Mounted Screens, Fabric

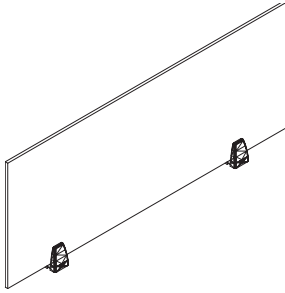

DESCRIPTION

Surface mounted fabric screens, including hardware

NOTES

- Includes: (2) supporting brackets for screens up to 48"W, (3) supporting brackets for screens 54"W and wider.
- Mounts to any laminate/veneer worksurface top.
- **Passage and Terrain fabric not approved for this application**

SPECIFICATION OPTIONS

product #: see charts below
Paint (Brackets) CW, BU, SV
fabric: see page 7 (Passage and Terrain fabric not approved for this application)

ORDER EXAMPLE

product #: FWSMTK.1424
paint: SV Silver
fabric: PF-101-2 Slide, Slate

Fabric Screens, 14" HIGH

PART #	HEIGHT	WIDTH	LIST
FWSMTK.1424	14"	24"	\$242
FWSMTK.1430	14"	30"	\$255
FWSMTK.1436	14"	36"	\$306
FWSMTK.1442	14"	42"	\$306
FWSMTK.1448	14"	48"	\$354
FWSMTK.1454	14"	54"	\$431
FWSMTK.1460	14"	60"	\$455
FWSMTK.1466	14"	66"	\$455
FWSMTK.1472	14"	72"	\$480

NOTES

- Screen mounts to any laminate/veneer worksurface top

Fabric Screens, 14" HIGH

PART #	HEIGHT	WIDTH	LIST
FWSMTK.1422	14"	22"	\$242
FWSMTK.1428	14"	28"	\$255

NOTES

- Screen mounts to any laminate/veneer worksurface top

Mobile Pedestal

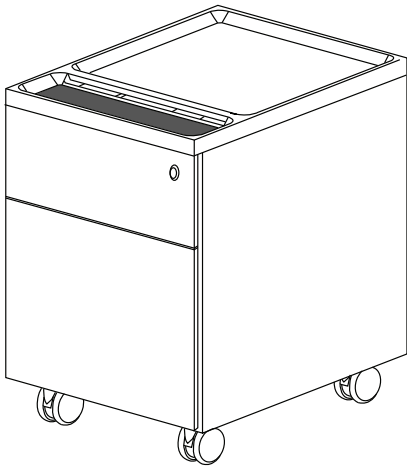

DESCRIPTION

Box/File mobile pedestal with lock and matching color top

SPECIFICATION OPTIONS

product #: FBFPED.MOB
finish: CW, BU, SV
foam color (if applicable): Charcoal, Green, Café, Grey, Blue and Red

NOTES

- Optional Foam cushion available
- Optional different color top available
- Foam cushion is available in 6 colors
- Key-alike available
- Changeable colored top available

ORDER EXAMPLE

Pedestal:
product #: FBFPED.MOB
finish: SV Silver
Cushion:
product #: FBFPED.CUSH
finish: Charcoal

MOBILE PEDESTAL

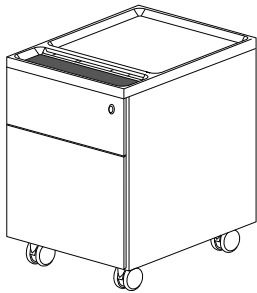

PART #	HEIGHT	WIDTH	DEPTH	WT. (LBS)	PRICE	NOTES
FBFPED.MOB	15"	15"	19 3/4"		\$600	<ul style="list-style-type: none"> • Finish options: SV Silver, CW Cloud White and BU Black Umber

COLOR PEDESTAL TOP

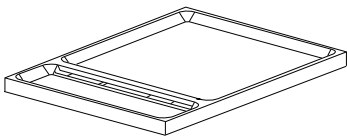

PART #	HEIGHT	WIDTH	DEPTH	PRICE	NOTES
FBFPED.PT				\$75	<ul style="list-style-type: none"> • Color options: Green, Blue, and Red • Please select color when ordering

FOAM CUSHION

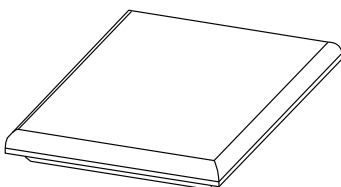

PART #	HEIGHT	WIDTH	DEPTH	WT. (LBS)	PRICE	NOTES
FBFPED.CUSH					\$125	<ul style="list-style-type: none"> • Color options: Charcoal, Green, Café, Grey, Blue and Red • Please select color when ordering • Cushion is made of foam and not fabric covered

Keyed Alike

DESCRIPTION

Keys for My-Hite pedestal

SPECIFICATION OPTIONS

product #: see charts below

ORDER EXAMPLE

product #: METAL1 -FMK

PART #	DESCRIPTION	PRICE	NOTES
METAL1-KEY-ALIKE-4	Lock Core Keyed-Alike (set of 4) - Type 1 Metal Storage	\$139	<ul style="list-style-type: none"> • All Friant Pedestals, Lateral Files, and Overhead Cabinets can be keyed-alike • Keyed-Alike Lock Cores are sold in sets of 4 or 6). • Each set includes four Lock Cores, each with two keys, all with the same lock number. • Lock core removal/change keys will need to be ordered separately. • Additional Lock Core Removal Keys and Master Keys are available.
METAL1-FCK	Lock Core Change Key - Type 1 Metal Storage	\$21	
METAL1-FMK	Lock Core Master Key - Type 1 Metal Storage	\$21	
METAL1-KEYBLANK	Key Blank - Type 1 Metal Storage	\$3	

Monitor Arms

SINGLE MONITOR ARM



PART #	LIST	NOTES
FMA-S	\$568	<ul style="list-style-type: none"> CW, SV, BU Finish Includes attachment hardware for clamp, grommet and Verity track mount.

DUAL MONITOR ARM



PART #	LIST	NOTES
FMA-D	\$811	<ul style="list-style-type: none"> CW, SV, BU Finish Includes attachment hardware for clamp, grommet and Verity track mount.

Power Grommet Worksurface Mounted

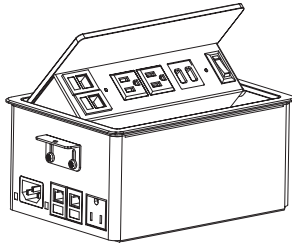

DESCRIPTION

Worksurface mounted power/data grommet

SPECIFICATION OPTIONS

product #: see charts below
finish: BA Brushed Aluminum, BC Brushed Charcoal or CW Cloud White (contact customer service for lead time)

NOTES

- Includes 8' coiled power cord to connect to power source, or daisy chain to next power grommet
- Optional 10' coiled power cord is sold separately

ORDER EXAMPLE

product #: FPWR.0608
finish: BA Brushed Aluminum

POWER GROMMET, 5x8

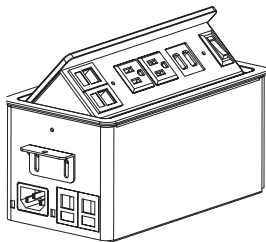

PART #	HEIGHT	WIDTH	DEPTH	PRICE
FPWR.0508		8"	5"	\$550

- NOTES
- Worksurface mounted power/data grommet, 5x8
 - Includes 8' coiled power cord to connect to power source
 - Optional 10' coiled power cord is sold separately
 - **Above Worksurface:** (2) CAT6 data ports (out), (2) power outlets, (2) USB ports
 - **Below Worksurface:** (2) CAT6 data ports (in), (1) power outlet, Daisy Chain ports (in/out)

POWER GROMMET, 6x8

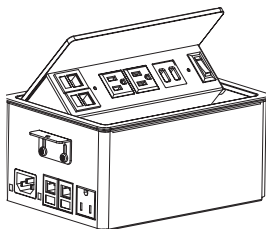

PART #	HEIGHT	WIDTH	DEPTH	PRICE
FPWR.0608		8"	6"	\$550

- NOTES
- Worksurface mounted power/data grommet, 6x8
 - Includes 8' coiled power cord to connect to power source
 - Optional 10' coiled power cord is sold separately
 - **Above Worksurface:** (2) CAT6 data ports (out), (2) power outlets, (2) USB ports
 - **Below Worksurface:** (2) CAT6 data ports (in), (2) power outlets, Daisy Chain ports (in/out)

GROMMET COILED POWER CORD

PART #	HEIGHT	WIDTH	DEPTH	PRICE
FPWRC-10		10'		\$60

- NOTES
- Optional 10' coiled power is sold separately.

Power Distribution

DESCRIPTION

Workstation accessories.

SPECIFICATION OPTIONS

product #: see charts below
finish: CW Cloud White, DT Dark Tone, MT Medium Tone

ORDER EXAMPLE

product #: FTB.24
finish: CW

SINGLE CIRCUIT INFEED



PART #

FD-BPI.1CIR

PRICE

\$82

NOTES

- Plug-in power infeed for use with table power distribution
- 8' cord

TABLE POWER DISTRIBUTION



PART #

FD-SFC-306-4A

\$71

NOTES

- Use with single circuit infeed (FD-BPI.1CIR)
- Power strip to attaches to the underside of tabletops.

DAISY CHAIN POWER CONNECTOR

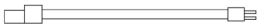

PART #

FD-DCI.1CIR

PRICE

\$82

NOTES

- Connects adjacent table power distribution 8' cord

Accessories

WIRE MANAGER

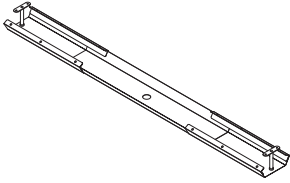

PART #	HEIGHT	WIDTH	DEPTH	LIST	NOTES
FMHWM	1 7/8"	32"- 59"	6"	\$81	<ul style="list-style-type: none"> Wire manager covers user's wiring (i.e.: computer, phone, etc.); adjustable width To use a wire manager on your My-Hite table with fabric covered privacy screen you must order "with gap". Wire manager telescopes from 32"- 59" Includes T-Support post with height of 3 1/4" Specify finish: CW, BU or SV

MESH WIRE MANAGER

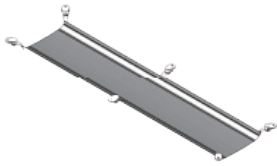

PART #	LENGTH	PRICE	NOTES
FFWM.18	18"	\$125	<ul style="list-style-type: none"> Wire manager mounts to the bottom of a worksurface to manage cords Finish: Black with red zipper
FFWM.34	34"	\$125	

CASTERS

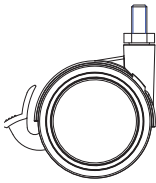

PART #	LIST	NOTES
FMHCS-3.4 Casters for 3-Stage Straight Bases (4 locking casters included)	\$150	<ul style="list-style-type: none"> There are 4 or 6 locking casters and are installed in the field. Order 4 casters for rectangle base and 6 casters for corner base Height of table is increased by 2" and will not be reflected on the display height
FMHCS-3.6 Casters for 3-Stage Corner Bases (6 locking casters included)	\$150	

CONVERSION KIT

PART #	LIST	NOTES
FCNAH.CONVERSION	\$1,250	<ul style="list-style-type: none"> Kit of parts to convert an existing 2 leg base to a 3 leg base . 24" T leg only

DESK MOUNTED POWER UNIT



PART #	PRICE	NOTES
FPWR.DM	\$375	<ul style="list-style-type: none"> Worksurface mounted power unit Includes 3 plugs and 2 USB ports finish: available in BU and CW

BEAM

How to Order Beam

1 Select a Beam Package

- Beam package with screen support
or
- Beam package without screen support

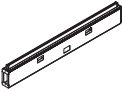
Choose	Specify Part #	Description	Specify Finish
	FB-BEAM-36A-E	Beam package with screen support	Silver

2 Specify End of Run Posts

- End of Run post for each end of run (Quantity (2) total each run)

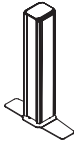
Choose	Specify Part # (Quantity 2)	Description
	FB-POSTEND	End of run post

3 Specify Support Posts

- Inline post for each package to package location (Quantity depends on length of run)
- 3 or 4 way post if applicable

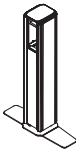
Choose	Specify Part # (Quantity TBD)	Description
	FB-POST180-X-D	Support post used in middle of run

4 Specify Electrical

Options include:

- Select either base feed or power pole (power pole at End of Run only - base feed at any post)
- Specify duplexes - Circuit 1-4 ((2) duplexes per side - **except** 36" which is (1) duplex per side)
- Add data port
(FBDPP - less than 20 CAT 6 cables)
(FHDPP - more than 20 CAT 6 cables)

Choose	Specify Part #
	FB-BPE

Choose	Specify Part #
Duplex	FIRECP4.I

Choose	Specify Part #
	FBDPP

5 Specify Beam Mounted Screen (if applicable)

Options include:

- Clear glass
- Frosted glass
- Fabric covered

Choose	Specify Part #	Material
	FB-GLS2436-FR	FROSTED GLASS

6 Specify My-Hite Base

Choose	Specify Part #
	FSQAHBT-24-3

7 Specify My-Hite Top for Beam Application

Options include:

- Tops range from 40" to 76"

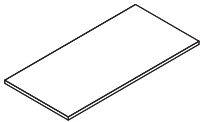
Choose	Specify Part #	Specify Finish
	FBRWS.XXXX	M28 Arctic

8 Select additional items to complete your system

Options include:

Monitor Arms



Mobile Pedestal



Power Grommet

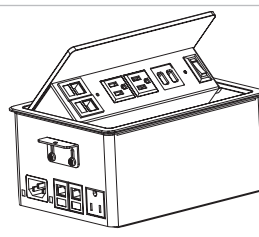

Worksurface Planning Guide

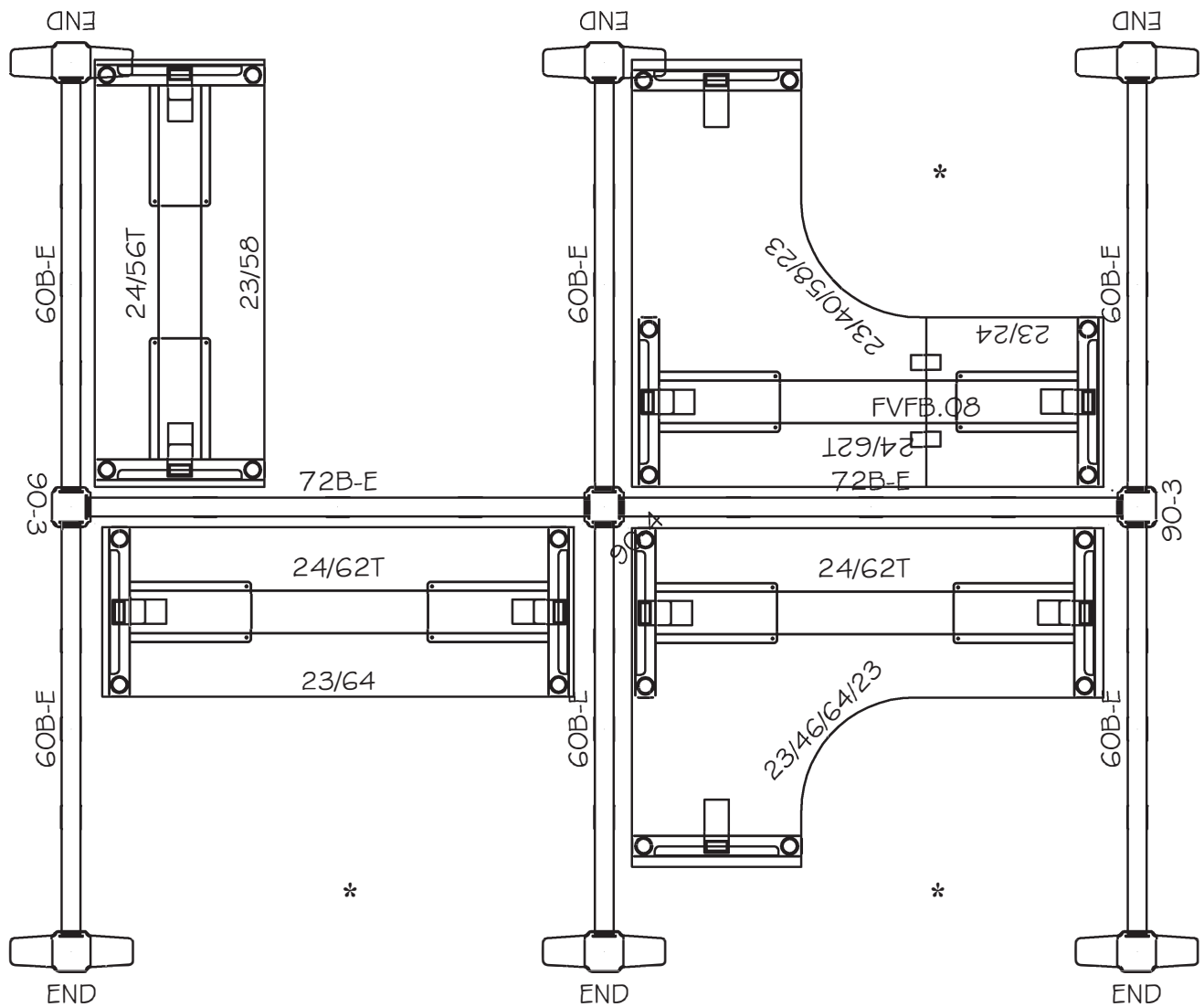

SPECIFY BEAM

* When worksurface is wrapped by Beam on 3 sides, width must be reduced one full size. For example: 70" worksurface becomes a 64"

Beam Elevation Height

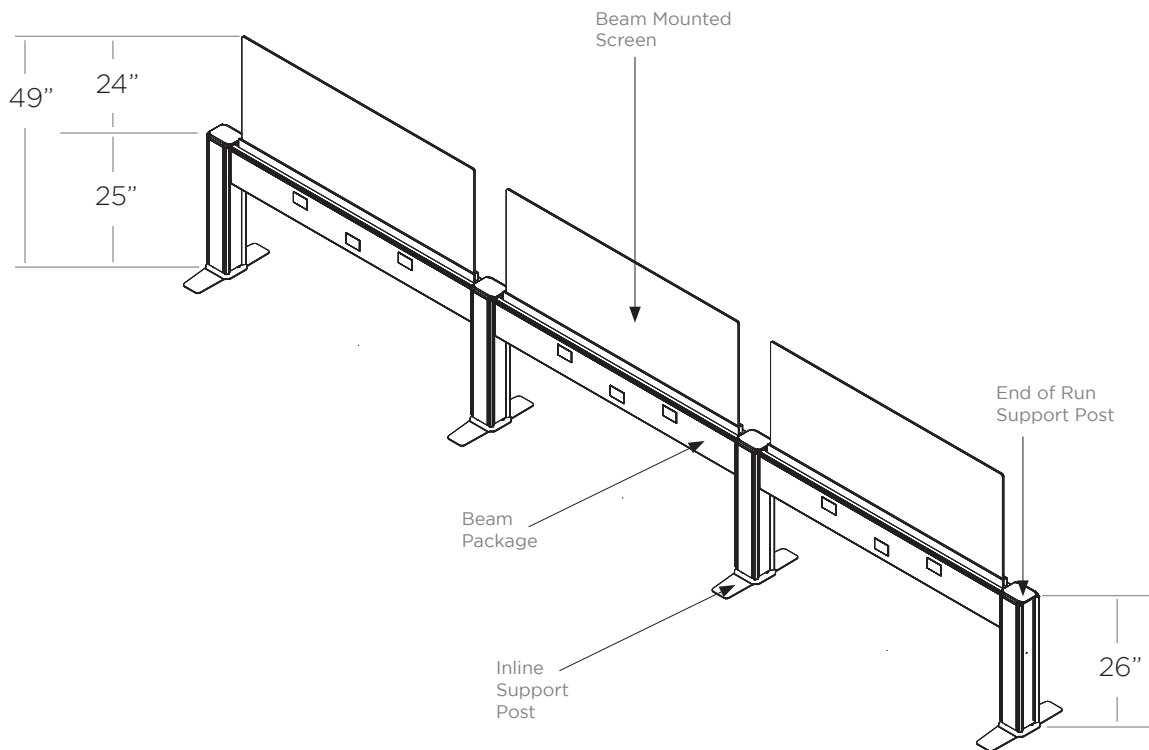
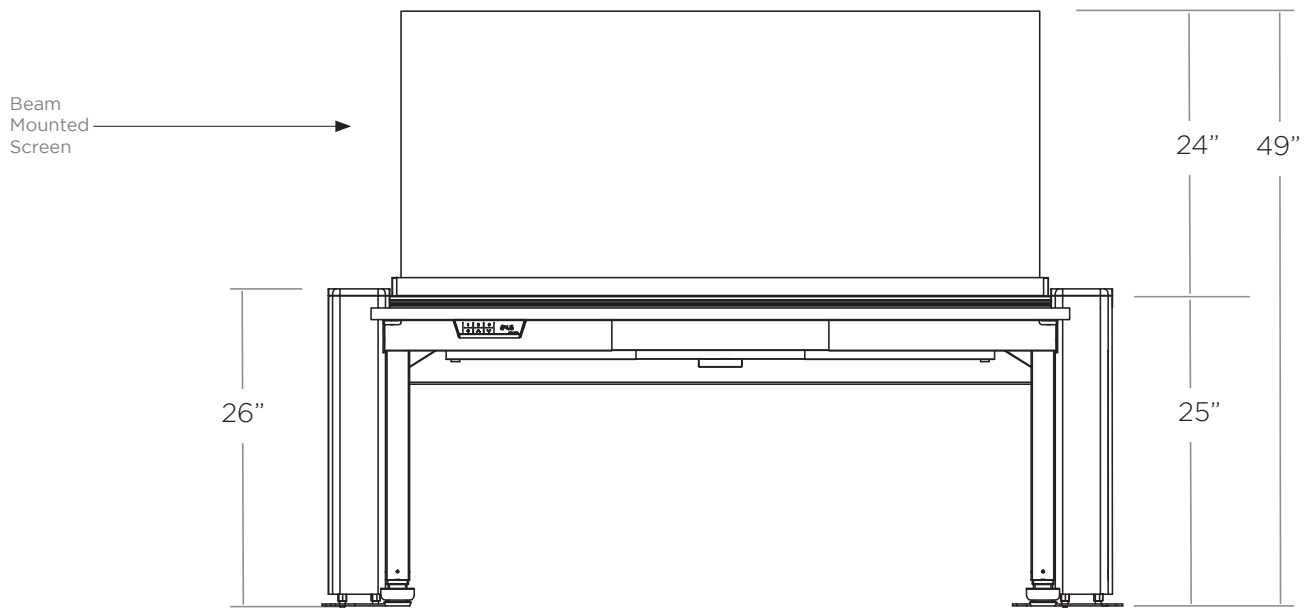

SPECIFY BEAM

Beam Creep

Beam width is measured from center of Post to center of Post. Because of this, creep will be consistent, no matter the size of the beam packages, or the quantity of posts in the run.

Beam creep will be an additional 5" overall per run.

Examples below are FB-BEAM-48B-E Beam Packages, 48"W

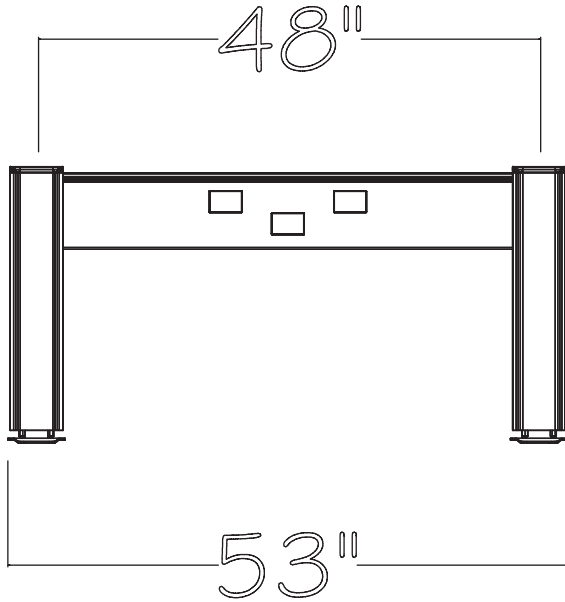

Single Station

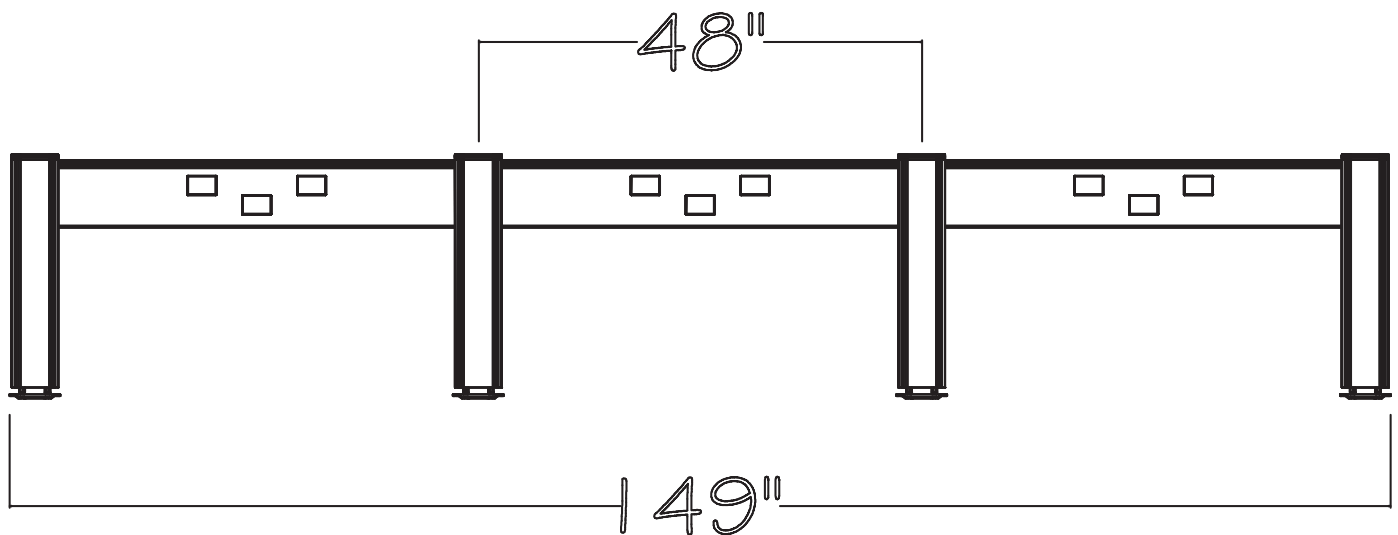

Three Station

Data Port Plate

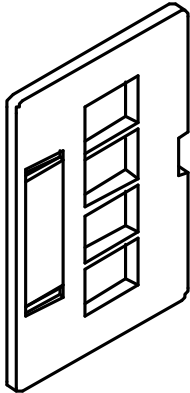
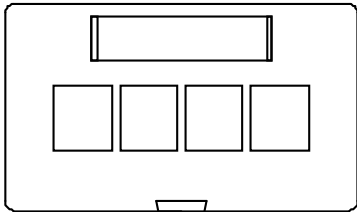

Product Description

PART #: FBDPP, FHDPP

This Data Port Faceplate is field configurable, flush-mounted onto the Panel Base Kickplate, and provides 1 to 4 flush-mount ports for a variety of snap-in connectors and adaptors.

Product Notes

- Installation and changes can be made without removing the Panel Base Kickplate
- Plates can be installed and removed without any tools
- Window ID provided with each Data Port Plate
- Release latch provides easy access to connections without any tools
- Blank inserts included with each Data Port Plate

Dimensions

PART #: FBDPP,

HEIGHT: 2¹/₈"

WIDTH: 3⁵/₈"

DEPTH: 0.25" (from face of Panel Base Kickplate)

MATERIAL: High impact plastic

PART #: FHDPP,

HEIGHT: 2¹/₈"

WIDTH: 3⁵/₈"

DEPTH: 0.75" (from face of Panel Base Kickplate)

MATERIAL: High impact plastic

Beam Package With power & data cutouts

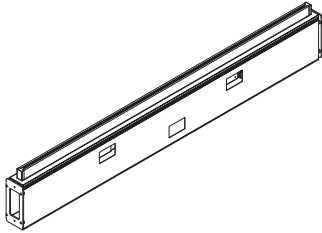

INCLUDES: Beam, Top cap & Base covers with power & data cutouts

DESCRIPTION

Beam package distributes power and data

NOTES

- Order data port plates separately
- All widths provide locations for duplexes; (2) on each side, (4) total per beam except 36": (1) duplex each side, (2) total per beam
- (1) Festoon included in package
- Order support posts separately
- Order infeed separately
- Order duplexes separately
- Order Data Port Plate separately

SPECIFICATION OPTIONS

product #: see charts below
finish: CW, BU, SV,

ORDER EXAMPLE

description: Beam package with screen support
product #: FB-BEAM-36A-E
finish: Silver SV

BEAM PACKAGE WITH SCREEN SUPPORT

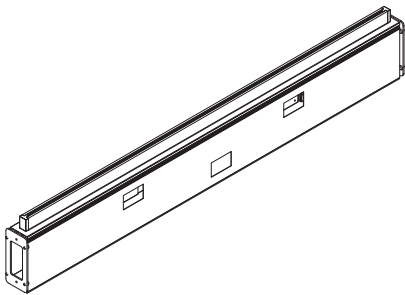

PART #	WIDTH	DEPTH	LIST
FB-BEAM-36A-E	36"	-	\$556
FB-BEAM-42A-E	42"	-	\$612
FB-BEAM-48A-E	48"	-	\$702
FB-BEAM-54A-E	54"	-	\$766
FB-BEAM-60A-E	60"	-	\$855
FB-BEAM-66A-E	66"	-	\$961
FB-BEAM-72A-E	72"	-	\$1,028

NOTES

- Powered data base covers included
- Non-powered base covers available separately, page 79
- Order screens separately

BEAM PACKAGE WITHOUT SCREEN SUPPORT

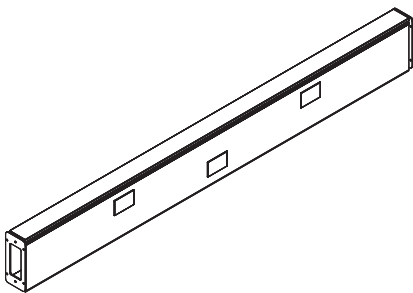

PART #	WIDTH	DEPTH	LIST
FB-BEAM-36B-E	36"	-	\$508
FB-BEAM-42B-E	42"	-	\$557
FB-BEAM-48B-E	48"	-	\$640
FB-BEAM-54B-E	54"	-	\$697
FB-BEAM-60B-E	60"	-	\$775
FB-BEAM-66B-E	66"	-	\$876
FB-BEAM-72B-E	72"	-	\$934

NOTES

- Powered data base covers included
- Non-powered base covers available separately, page 79

Beam Package Without cutouts

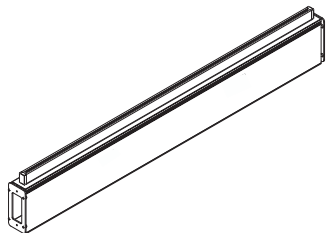

DESCRIPTION

Beam package without cutout

NOTES

- (1) Festoon included in package
- Order support posts separately
- Order infeed separately

SPECIFICATION OPTIONS

product #: see charts below
finish: SV, BU, CW

ORDER EXAMPLE

description: Beam package with screen support
product #: FB-BEAM-72B-E.NC
finish: Silver SV

INCLUDES: Beam, Top cap & Base covers without power & data cutouts

BEAM PACKAGE WITHOUT SCREEN SUPPORT

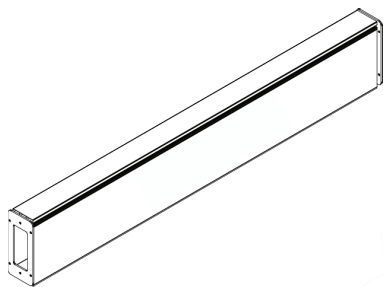

PART #	WIDTH	DEPTH	LIST	NOTES
FB-BEAM-36B-E.NC	36"	-	\$503	• Non-powered data base covers included
FB-BEAM-42B-E.NC	42"	-	\$553	
FB-BEAM-48B-E.NC	48"	-	\$635	
FB-BEAM-54B-E.NC	54"	-	\$692	
FB-BEAM-60B-E.NC	60"	-	\$771	
FB-BEAM-66B-E.NC	66"	-	\$871	
FB-BEAM-72B-E.NC	72"	-	\$929	

BEAM PACKAGE WITH SCREEN SUPPORT

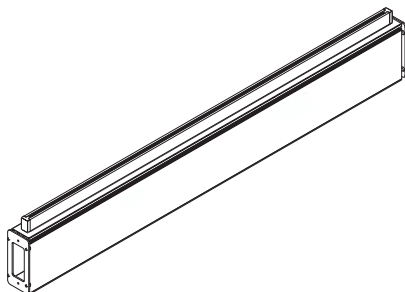

PART #	WIDTH	DEPTH	LIST	NOTES
FB-BEAM-36A-E.NC	36"	-	\$552	• Non-powered data base covers included. • Order screens separately
FB-BEAM-42A-E.NC	42"	-	\$608	
FB-BEAM-48A-E.NC	48"	-	\$697	
FB-BEAM-54A-E.NC	54"	-	\$760	
FB-BEAM-60A-E.NC	60"	-	\$850	
FB-BEAM-66A-E.NC	66"	-	\$956	
FB-BEAM-72A-E.NC	72"	-	\$1,024	

Supporting Post Inline & End of Run

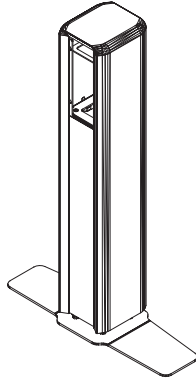

DESCRIPTION

Posts support beam packages

SPECIFICATION OPTIONS

product #: see charts below
finish: Silver, Cloud White, Black Umber

NOTES

- Posts support beam packages

ORDER EXAMPLE

description: Beam inline 180° supporting post
product #: FB-POST180
finish: SV Silver

INLINE POST 180°

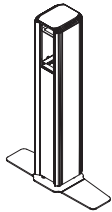

PART #	HEIGHT	WIDTH	DEPTH	WT. (LBS)	PRICE	NOTES
FB-POST180					\$677	<ul style="list-style-type: none"> • Use inline, between (2) beam packages

END OF RUN POST

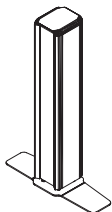

PART #	HEIGHT	WIDTH	DEPTH	WT. (LBS)	PRICE	NOTES
FB-POSTEND					\$633	<ul style="list-style-type: none"> • Use at end of run

SPECIFY BEAM

Supporting Post 2, 3, 4 Way

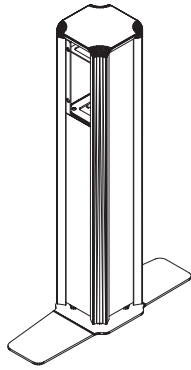

DESCRIPTION

Posts support beam packages

SPECIFICATION OPTIONS

product #: see charts below
finish: Silver, Cloud White, Black Umber

ORDER EXAMPLE

description: 3 way supporting post 90°
product #: FB-POST90-3
finish: SV Silver

2-WAY POST 90°

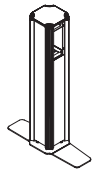

PART #	HEIGHT	WIDTH	DEPTH	WT. (LBS)	PRICE	NOTES
FB-POST90-2-D					\$651	• Use at 2-way, 90°

3-WAY POST 90°

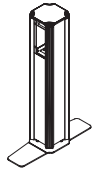

PART #	HEIGHT	WIDTH	DEPTH	WT. (LBS)	PRICE	NOTES
FB-POST90-3					\$738	• Use at 3-way, 90°

4-WAY POST 90°

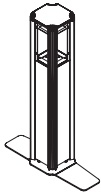

PART #	HEIGHT	WIDTH	DEPTH	WT. (LBS)	PRICE	NOTES
FB-POST90-4					\$738	• Use at 4-way, 90°

2-WAY POST 120°

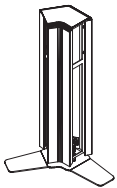

PART #	HEIGHT	WIDTH	DEPTH	WT. (LBS)	PRICE	NOTES
FB-POST120-2					\$741	• Use at 2-way, 120°

3-WAY POST 120°

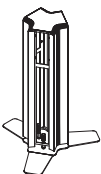

PART #	HEIGHT	WIDTH	DEPTH	WT. (LBS)	PRICE	NOTES
FB-POST120-3					\$810	• Use at 3-way, 120°

SPECIFY BEAM

Laminate Insert Package

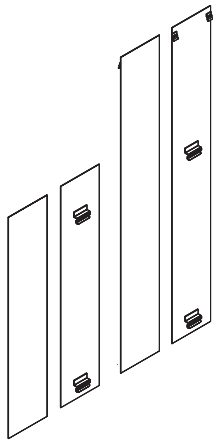

DESCRIPTION

Laminate insert packages for Beam posts

SPECIFICATION OPTIONS

product #: see charts below
laminate: see page 9

ORDER EXAMPLE

product #: FB-POST180-LAM
laminate: M28 Arctic

LAMINATE INSERT PACKAGE FOR INLINE POST 180°

PART #	HEIGHT	WIDTH	DEPTH	WT. (LBS)	PRICE	NOTES
FB-POST180-LAM	17.5"	3.5"			\$104	Includes • (2) Short Inserts

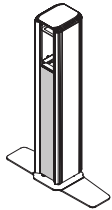

LAMINATE INSERT PACKAGE FOR END OF RUN POST

PART #	HEIGHT	WIDTH	DEPTH	WT. (LBS)	PRICE	NOTES
FB-POSTEND-LAM	17.5"/25"	3.5"			\$108	Includes • (1) Short Insert • (1) Tall Insert

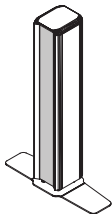

LAMINATE INSERT PACKAGE FOR 2-WAY POST 90°

PART #	HEIGHT	WIDTH	DEPTH	WT. (LBS)	PRICE	NOTES
FB-POST90-2-DLAM	17.5"/25"	3.5"			\$217	Includes • (2) Short Inserts • (2) Tall Inserts

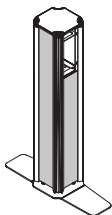

SPECIFY BEAM

LAMINATE INSERT PACKAGE FOR 3-WAY POST 90°

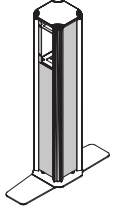

PART #	HEIGHT	WIDTH	DEPTH	WT. (LBS)	PRICE
FB-POST90-3LAM	17.5"/25"	3.5"			\$213

NOTES

- Includes
- (3) Short Inserts
 - (1) Tall Insert

LAMINATE INSERT PACKAGE FOR 4-WAY POST

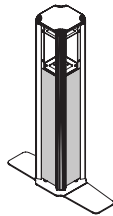

PART #	HEIGHT	WIDTH	DEPTH	WT. (LBS)	PRICE
FB-POST90-4LAM	17.5"	3.5"			\$208

NOTES

- Includes
- (4) Short Inserts

LAMINATE INSERT PACKAGE FOR 2-WAY POST 120°

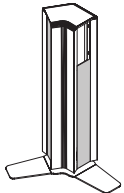

PART #	HEIGHT	WIDTH	DEPTH	WT. (LBS)	PRICE
FB-POST120-2LAM	17.5"	3.5"			\$104

NOTES

- Includes
- (2) Short Inserts

LAMINATE INSERT PACKAGE FOR 3-WAY POST 120°

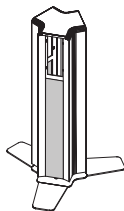

PART #	HEIGHT	WIDTH	DEPTH	WT. (LBS)	PRICE
FB-POST120-3LAM	17.5"	3.5"			\$156

NOTES

- Includes
- (3) Short Inserts

SPECIFY BEAM

Beam Base Cover, non-powered



DESCRIPTION

Base cover without power/data knockout

SPECIFICATION OPTIONS

product #: see charts below
finish: SV, BU, CW

NOTES

- Beam package includes power/data base covers

ORDER EXAMPLE

description: Non-powered Beam basecover
product #: FATB-BC-N-48
finish: Silver SV

PART #	LIST
FATB-BC-N-36	\$45
FATB-BC-N-42	\$53
FATB-BC-N-48	\$61
FATB-BC-N-54	\$68
FATB-BC-N-60	\$74
FATB-BC-N-66	\$81
FATB-BC-N-72	\$87

NOTES

- Non-powered base cover
- Order (1) for each side if needed

SPECIFY BEAM

Beam Package Top Caps

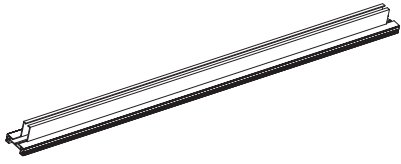

DESCRIPTION

Top cap only.

SPECIFICATION OPTIONS

product #: see charts below
finish: See page 9

NOTES

- Top cap is included in beam package #FB-BEAM-XXX-E
- Includes attachment hardware
- Order new top cap to match the size and finish of the original beam package
- **This top cap sold separately for reconfiguration purposes**

ORDER EXAMPLE

description: Top cap for beam packages
product #: FB-TOPCAP-36-A-XX
finish: Silver SV

BEAM TOP CAP WITH SCREEN SUPPORT

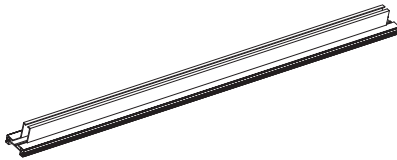

PART #	WIDTH	DEPTH	LIST
FB-TOPCAP-36-A	36"	-	\$204
FB-TOPCAP-42-A	42"	-	\$224
FB-TOPCAP-48-A	48"	-	\$246
FB-TOPCAP-54-A	54"	-	\$266
FB-TOPCAP-60-A	60"	-	\$293
FB-TOPCAP-66-A	66"	-	\$311
FB-TOPCAP-72-A	72"	-	\$337

NOTES

- Order screens separately. (see page 54)

BEAM TOP CAP WITHOUT SCREEN SUPPORT



PART #	WIDTH	DEPTH	LIST
FB-TOPCAP-36-B	36"	-	\$77
FB-TOPCAP-42-B	42"	-	\$88
FB-TOPCAP-48-B	48"	-	\$100
FB-TOPCAP-54-B	54"	-	\$112
FB-TOPCAP-60-B	60"	-	\$124
FB-TOPCAP-66-B	66"	-	\$135
FB-TOPCAP-72-B	72"	-	\$149

SPECIFY BEAM

Beam Electrical Distribution

DESCRIPTION	SPECIFICATION OPTIONS
Electrical distribution components	product #: see charts below finish: see page X
NOTES	ORDER EXAMPLE
<ul style="list-style-type: none"> • Circuit 4 is dedicated • Power is 8 wire, (4) 20 AMP circuit • Receptacles are rated 120V, 15 AMPS 	product #: FIRECP4.1 finish: CW

RECEPTACLE 4-CIRCUITS

PART #	HEIGHT	WIDTH	DEPTH	WT. (LBS)	PRICE	NOTES
FIRECP4.I	circuit I	—	—	0.25"	\$27	<ul style="list-style-type: none"> • Provides access to I, II, III, IIII circuit • Provides dedicated circuit with "IIII" receptacle • CW, SV, BU • Receptacle -CONT are permanently marked CONTROLLED on the face of the receptacle and must be connected to a timer or motion sensor at the infeed location by a licensed electrician in order to comply with California T24
FIRECP4.II	circuit II	—	—	0.25"	\$27	
FIRECP4.III	circuit III	—	—	0.25"	\$27	
FIRECP4.IIII	circuit IIII (dedicated)	—	—	0.25"	\$27	
FIRECP4.II-CONT	Circuit II	—	—	0.25"	\$27	
FIRECP4.III-CONT	Circuit III	—	—	0.25"	\$27	

DATA PORT PLATE

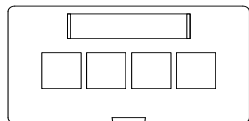

PART #	HEIGHT	WIDTH	DEPTH	WT. (LBS)	PRICE	NOTES
FBDPP	2.125"	3.625"	0.250"	0.10	\$45	<ul style="list-style-type: none"> • If running more than (20) data cables, use FHDPP. • If running less than (20) data cables, use FB DPP. • SV, CW or BU
FHDPP	2.125"	3.625"	0.750"	0.10	\$45	

SPECIFY BEAM

Beam Electrical Distribution, cont'd

BASE POWER ENTRY

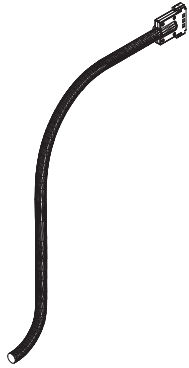

PART #	HEIGHT	WIDTH	DEPTH	WT. (LBS)	PRICE
FB-BPE		6"			\$327

NOTES

- Base power entry, 4 circuit, for use with Beam product.

CEILING POWER ENTRY

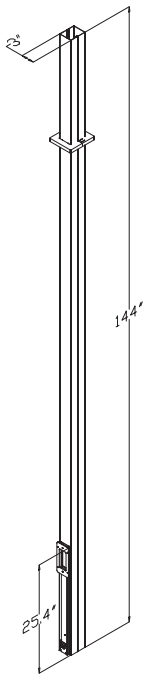

PART #	HEIGHT	WIDTH	DEPTH	WT. (LBS)	PRICE
FB-CPE					\$791

NOTES

- Ceiling power entry, 4 circuit, for use with Beam product.
- CW, SV, BU

SPECIFY BEAM

Beam Mounted Screens

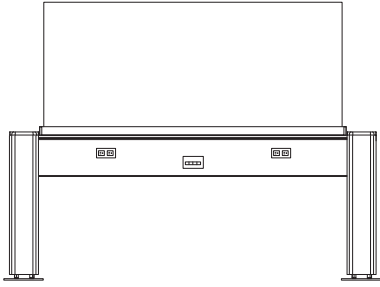

DESCRIPTION

Privacy screens for use with beam product

SPECIFICATION OPTIONS

product #: see charts below

NOTES

- For use with beam packages with screen support: i.e. FB-BEAM-42A-E
- Includes mounting hardware
- Actual screen is 7" shorter than Beam Package

ORDER EXAMPLE

product #: FB-FBS2436
fabric: PF1010-3 Slide Pewter

FROSTED GLASS SCREEN

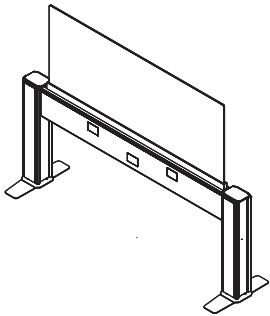

PART #	WIDTH	HEIGHT	LIST
FB-GLS2436-FR	29"	24"	\$289
FB-GLS2442-FR	35"	24"	\$331
FB-GLS2448-FR	41"	24"	\$360
FB-GLS2454-FR	47"	24"	\$401
FB-GLS2460-FR	53"	24"	\$442
FB-GLS2466-FR	59"	24"	\$483
FB-GLS2472-FR	65"	24"	\$525

NOTES

- Price is for (1) screen

CLEAR GLASS SCREEN

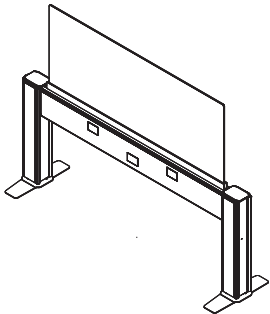

PART #	WIDTH	HEIGHT	LIST
FB-GLS2436-CL	29"	24"	\$176
FB-GLS2442-CL	35"	24"	\$199
FB-GLS2448-CL	41"	24"	\$214
FB-GLS2454-CL	47"	24"	\$236
FB-GLS2460-CL	53"	24"	\$259
FB-GLS2466-CL	59"	24"	\$281
FB-GLS2472-CL	65"	24"	\$303

NOTES

- Price is for (1) screen

FABRIC COVERED SCREEN

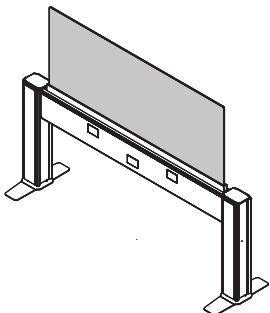

PART #	WIDTH	HEIGHT	LIST
FB-FBS2436	29"	24"	\$473
FB-FBS2442	35"	24"	\$493
FB-FBS2448	41"	24"	\$513
FB-FBS2454	47"	24"	\$539
FB-FBS2460	53"	24"	\$560
FB-FBS2466	59"	24"	\$586
FB-FBS2472	65"	24"	\$608

NOTES

- Price is for (1) screen
- Screens are magnetic, not tackable
- Passage and Terrain fabric not approved for this application

WORKSURFACES FOR USE WITH BEAM

Rectangular

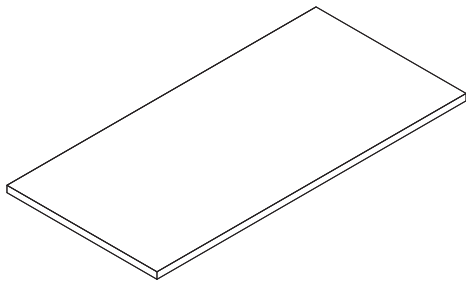

DESCRIPTION

Worksurface top only, for use with height adjustable base within workstation application

NOTES

- Add grommet (add \$75 list) Specify GL, GC, GR
- Order base separately from MY-HITE pricebook

Note: Top size reduced 1" in depth and 2" in width to fit within system workstation and prevent pinch points. We do not recommend using full size worktop in paneled workstation applications.

SPECIFICATION OPTIONS

product #: see charts below
worksurface finish: see page 9
edge finish: see page 9

ORDER EXAMPLE

product #: FBRWS.2340
worksurface finish: Light Maple, M1
edge finish: DT Dark Tone, E12
grommet: GC (Rear Center)
grommet color: Cloud White

RECTANGULAR WORKSURFACE, 23" DEEP

PART #	WIDTH	DEPTH	PRICE
FBRWS.2340	40"	23"	\$247
FBRWS.2346	46"	23"	\$252
FBRWS.2352	52"	23"	\$289
FBRWS.2358	58"	23"	\$315
FBRWS.2364	64"	23"	\$351
FBRWS.2370	70"	23"	\$360
FBRWS.2376	76"	23"	\$444
FBRWS.2382	82"	23"	\$544

NOTES

- Sizes are actual for example FBRWS.2370 is 23' x 70"

RECTANGULAR WORKSURFACE, 29" DEEP

PART #	WIDTH	DEPTH	PRICE
FBRWS.2940	40"	29"	\$317
FBRWS.2946	46"	29"	\$325
FBRWS.2952	52"	29"	\$368
FBRWS.2958	58"	29"	\$394
FBRWS.2964	64"	29"	\$440
FBRWS.2970	70"	29"	\$449
FBRWS.2976	76"	29"	\$552
FBRWS.2982	82"	29"	\$652

NOTES

- Sizes are actual for example FBRWS.2970 is 29' x 70"

RECTANGULAR WORKSURFACE, 35" DEEP

PART #	WIDTH	DEPTH	PRICE
FBRWS.3540	40"	35"	\$382
FBRWS.3546	46"	35"	\$389
FBRWS.3552	52"	35"	\$681
FBRWS.3558	58"	35"	\$689
FBRWS.3564	64"	35"	\$696
FBRWS.3570	70"	35"	\$704
FBRWS.3576	76"	35"	\$711
FBRWS.3582	82"	35"	\$811

NOTES

- Sizes are actual for example FBRWS.3570 is 35' x 70"

Corner

MY-HITE WORKSURFACES - BEAM APPLICATION

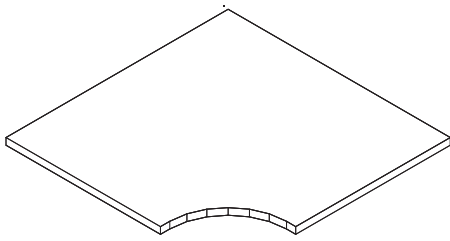

DESCRIPTION

Corner worksurface top only, for use with height adjustable base within workstation application.

NOTES

- Add grommet (add \$75 list) Specify GL, GC, GR
- Order base separately from MY-HITE pricebook

Note: Top size reduced 1" in depth and 2" in with to fit within system workstation and prevent pinch points. We do not recommend using full size worktop in paneled workstation applications.

SPECIFICATION OPTIONS

product #: see charts below
edge finish: see page 9
worksurface finish: see page 9

ORDER EXAMPLE

product #: FBCWS.2340
edge finish: DT Dark Tone, E12
worksurface finish: Light Maple, M1
grommet: GC (Rear Center)
grommet color: Cloud White

CORNER WORKSURFACE

PART #	WIDTH	DEPTH	PRICE
FBCWS.2340	40"	23"	\$404
FBCWS.2346	46"	23"	\$427
FBCWS.2940	40"	29"	\$439
FBCWS.2946	46"	29"	\$462

NOTES

- Sizes are actual for example FBCWS.2346 is 23" x 46"

90° Extended Curved Corner

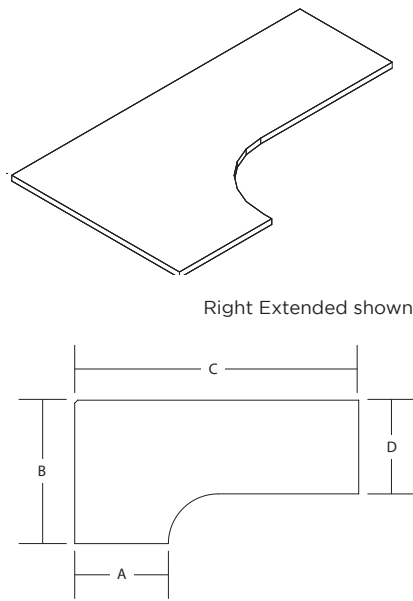

DESCRIPTION

Laminate worksurface with 3mm PVC edge

NOTES

- Worksurface top only, for use with height adjustable base within workstation application
- See My-Hite pricebook for use inside a freestanding application
- Add circular grommet (add \$75 list) Specify grommet placement GL, GC, GR
- Top size reduced 1" in depth and 2" in width to fit within system workstation and prevent pinch points.
- We do not recommend using full size worktop in paneled workstation applications

SPECIFICATION OPTIONS

product #: see charts below
edge finish: see page 9
worksurface finish: see page 9
left or right extended: L for Left, R for Right

ORDER EXAMPLE

product #: FBECWS.23345823L
top, edge finish: E10 Espresso
worksurface finish: M11 Light Walnut

**23" D CONNECTING SIDE
 23" D EXTENSION
 34" D**

PART #	HEIGHT	A	B	C	D	PRICE
FBECWS.23345823L	1.25"	23"	34"	58"	23"	\$475
FBECWS.23345823R	1.25"	23"	34"	58"	23"	\$475
FBECWS.23346423L	1.25"	23"	34"	64"	23"	\$529
FBECWS.23346423R	1.25"	23"	34"	64"	23"	\$529
FBECWS.23347023L	1.25"	23"	34"	70"	23"	\$538
FBECWS.23347023R	1.25"	23"	34"	70"	23"	\$538
FBECWS.23347623L	1.25"	23"	34"	76"	23"	\$645
FBECWS.23347623R	1.25"	23"	34"	76"	23"	\$645
FBECWS.23348223L	1.25"	23"	34"	82"	23"	\$752
FBECWS.23348223R	1.25"	23"	34"	82"	23"	\$752

**29" D CONNECTING SIDE
 29" D EXTENSION
 34" D**

PART #	HEIGHT	A	B	C	D	PRICE
FBECWS.29345829L	1.25"	29"	34"	58"	29"	\$520
FBECWS.29345829R	1.25"	29"	34"	58"	29"	\$520
FBECWS.29346429L	1.25"	29"	34"	64"	29"	\$573
FBECWS.29346429R	1.25"	29"	34"	64"	29"	\$573
FBECWS.29347029L	1.25"	29"	34"	70"	29"	\$582
FBECWS.29347029R	1.25"	29"	34"	70"	29"	\$582
FBECWS.29347629L	1.25"	29"	34"	76"	29"	\$689
FBECWS.29347629R	1.25"	29"	34"	76"	29"	\$689
FBECWS.29348229L	1.25"	29"	34"	82"	29"	\$796
FBECWS.29348229R	1.25"	29"	34"	82"	29"	\$796

MY-HITE WORKSURFACES - BEAM APPLICATION

**23" D CONNECTING SIDE
23" D EXTENSION
40" D**

PART #	HEIGHT	A	B	C	D	PRICE
FBECWS.23405823L	1.25"	23"	40"	58"	23"	\$571
FBECWS.23405823R	1.25"	23"	40"	58"	23"	\$571
FBECWS.23406423L	1.25"	23"	40"	64"	23"	\$643
FBECWS.23406423R	1.25"	23"	40"	64"	23"	\$643
FBECWS.23407023L	1.25"	23"	40"	70"	23"	\$652
FBECWS.23407023R	1.25"	23"	40"	70"	23"	\$652
FBECWS.23407623L	1.25"	23"	40"	76"	23"	\$791
FBECWS.23407623R	1.25"	23"	40"	76"	23"	\$791
FBECWS.23408223L	1.25"	23"	40"	82"	23"	\$930
FBECWS.23408223R	1.25"	23"	40"	82"	23"	\$930

**29" D CONNECTING SIDE
29" D EXTENSION
40" D**

PART #	HEIGHT	A	B	C	D	PRICE
FBECWS.29405829L	1.25"	29"	40"	58"	29"	\$615
FBECWS.29405829R	1.25"	29"	40"	58"	29"	\$615
FBECWS.29406429L	1.25"	29"	40"	64"	29"	\$687
FBECWS.29406429R	1.25"	29"	40"	64"	29"	\$687
FBECWS.29407029L	1.25"	29"	40"	70"	29"	\$696
FBECWS.29407029R	1.25"	29"	40"	70"	29"	\$696
FBECWS.29407629L	1.25"	29"	40"	76"	29"	\$835
FBECWS.29407629R	1.25"	29"	40"	76"	29"	\$835
FBECWS.29408229L	1.25"	29"	40"	82"	29"	\$974
FBECWS.29408229R	1.25"	29"	40"	82"	29"	\$974

**23" D CONNECTING SIDE
23" D EXTENSION
46" D**

PART #	HEIGHT	A	B	C	D	PRICE
FBECWS.23465823L	1.25"	23"	46"	58"	23"	\$580
FBECWS.23465823R	1.25"	23"	46"	58"	23"	\$580
FBECWS.23466423L	1.25"	23"	46"	64"	23"	\$652
FBECWS.23466423R	1.25"	23"	46"	64"	23"	\$652
FBECWS.23467023L	1.25"	23"	46"	70"	23"	\$667
FBECWS.23467023R	1.25"	23"	46"	70"	23"	\$667
FBECWS.23467623L	1.25"	23"	46"	76"	23"	\$813
FBECWS.23467623R	1.25"	23"	46"	76"	23"	\$813
FBECWS.23468223L	1.25"	23"	46"	82"	23"	\$959
FBECWS.23468223R	1.25"	23"	46"	82"	23"	\$959

**29" D CONNECTING SIDE
29" D EXTENSION
46" D**

PART #	HEIGHT	A	B	C	D	PRICE
FBECWS.29465829L	1.25"	29"	46"	58"	29"	\$625
FBECWS.29465829R	1.25"	29"	46"	58"	29"	\$625
FBECWS.29466429L	1.25"	29"	46"	64"	29"	\$696
FBECWS.29466429R	1.25"	29"	46"	64"	29"	\$696
FBECWS.29467029L	1.25"	29"	46"	70"	29"	\$712
FBECWS.29467029R	1.25"	29"	46"	70"	29"	\$712
FBECWS.29467629L	1.25"	29"	46"	76"	29"	\$857
FBECWS.29467629R	1.25"	29"	46"	76"	29"	\$857
FBECWS.29468229L	1.25"	29"	46"	82"	29"	\$1,002
FBECWS.29468229R	1.25"	29"	46"	82"	29"	\$1,002

Rectangular Extension Freestanding Application

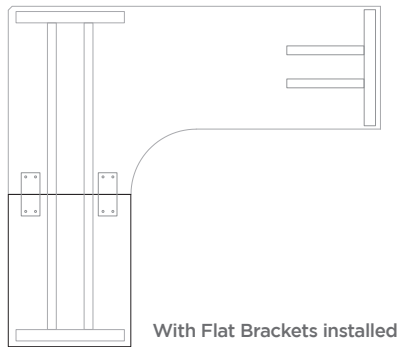

DESCRIPTION

Laminate worksurface with 3mm PVC edge

NOTES

- For use in combination with Extended Corner Worksurfaces and Corner My-Hite Bases only
- Not for use alone, nor with straight bases
- Maximum width combined: 72x96" or 84x84"

SPECIFICATION OPTIONS

product #: see charts below
worksurface finish: see page 9
edge finish: see page 9

ORDER EXAMPLE

product #: FBRWS.2324
worksurface finish: Light Maple, M1
edge finish: DT Dark Tone, E12

RECTANGULAR WORKSURFACE

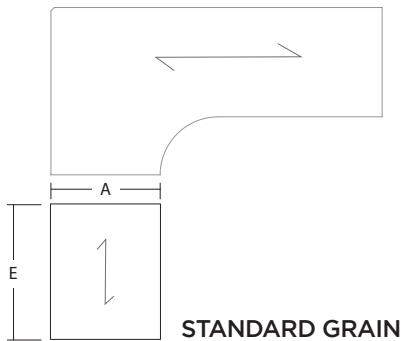

PART #	DEPTH "A"	WIDTH "E"	LIST	NOTES
FBRWS.2324	23"	24"	\$241	• Standard default grain direction is left to right (See left)
FBRWS.2330	23"	30"	\$276	
FBRWS.2336	23"	36"	\$285	
FBRWS.2924	29"	24"	\$320	
FBRWS.2930	29"	30"	\$365	
FBRWS.2936	29"	36"	\$374	

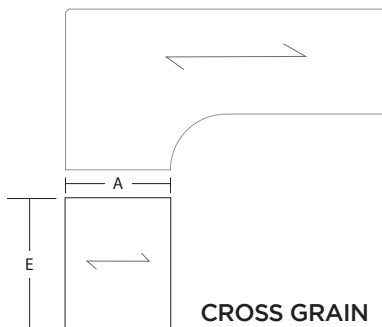

PART #	DEPTH "A"	WIDTH "E"	LIST	NOTES
FBRWS.2324-CG	23"	24"	\$289	• Cross grain direction is front to back (See left)
FBRWS.2330-CG	23"	30"	\$331	
FBRWS.2336-CG	23"	36"	\$342	
FBRWS.2924-CG	29"	24"	\$384	
FBRWS.2930-CG	29"	30"	\$438	
FBRWS.2936-CG	29"	36"	\$449	

D-Shaped

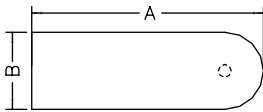
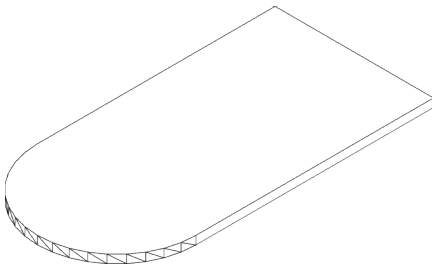

DESCRIPTION

Worksurface top only, for use with height adjustable base within workstation application

NOTES

- Add grommet (add \$75 list)
Location is GC
- Order base separately from MY-HITE pricebook

Note: Top size reduced 1" in depth and 2" in width to fit within system workstation and prevent pinch points. We do not recommend using full size worktop in paneled workstation applications.

SPECIFICATION OPTIONS

product #: see charts below
edge finish: see page 9
worksurface finish: see page 9

ORDER EXAMPLE

product #: FBEDSP.2346
edge finish: DT Dark Tone, E12
worksurface finish: Espresso, M10
grommet: GC (Rear Center)
grommet color: Cloud White

D-SHAPED

PART #	HEIGHT	A	B	C	D	PRICE
FBEDSP.2346	1.25"	46"	23"	—	—	\$369
FBEDSP.2358	1.25"	58"	23"	—	—	\$413
FBEDSP.2946	1.25"	46"	29"	—	—	\$405
FBEDSP.2958	1.25"	58"	29"	—	—	\$448
FBEDSP.2970	1.25"	70"	29"	—	—	\$491
FBEDSP.3570	1.25"	70"	35"	—	—	\$542

NOTES

- Sizes are actual for example FBEDSP.2346 is 23" x 46"

Wedge

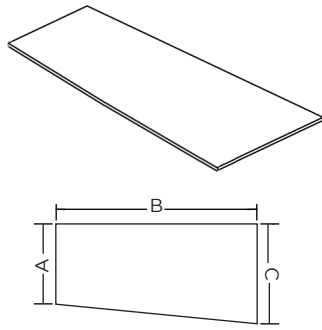

DESCRIPTION

Worksurface top only, for use with height adjustable base within workstation application

NOTES

- Add grommet (add \$75 list)
Specify GL, GC, GR
- Order base separately from MY-HITE pricebook

Note: Top size reduced 1" in depth and 2" in width to fit within system workstation and prevent pinch points. We do not recommend using full size worktop in paneled workstation applications.

SPECIFICATION OPTIONS

product #: see charts below
edge finish: see page 9
worksurface finish: see page 9

ORDER EXAMPLE

product #:FBWDWS.234029
edge finish: DT Dark Tone, E12
worksurface finish: Espresso, M10
grommet: GC (Rear Center)
grommet color: Cloud White

**23"D LEFT
29"D RIGHT**

PART #	HEIGHT	A	B	C	D	PRICE
FBWDWS.234029	1.25"	23"	40"	29"	—	\$328
FBWDWS.234629	1.25"	23"	46"	29"	—	\$335
FBWDWS.235229	1.25"	23"	52"	29"	—	\$380
FBWDWS.235829	1.25"	23"	58"	29"	—	\$407
FBWDWS.236429	1.25"	23"	64"	29"	—	\$454
FBWDWS.237029	1.25"	23"	70"	29"	—	\$464
FBWDWS.237629	1.25"	23"	76"	29"	—	\$540

**29"D LEFT
23"D RIGHT**

PART #	HEIGHT	A	B	C	D	PRICE
FBWDWS.294023	1.25"	29"	40"	23"	—	\$328
FBWDWS.294623	1.25"	29"	46"	23"	—	\$335
FBWDWS.295223	1.25"	29"	52"	23"	—	\$380
FBWDWS.295823	1.25"	29"	58"	23"	—	\$407
FBWDWS.296423	1.25"	29"	64"	23"	—	\$454
FBWDWS.297023	1.25"	29"	70"	23"	—	\$464
FBWDWS.297623	1.25"	29"	76"	23"	—	\$540

120° Corner / 90° Ends

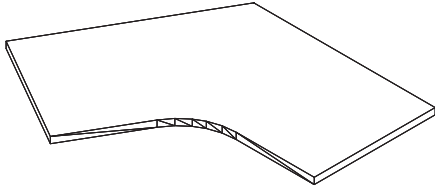

DESCRIPTION

Worksurface top only, for use with height adjustable base within workstation application

NOTES

- Add grommet (add \$75 list)
Specify GL, GC, GR
- Order base separately from MY-HITE pricebook

Note: Top size reduced 1" in depth and 2" in width to fit within system workstation and prevent pinch points. We do not recommend using full size worktop in paneled workstation applications.

SPECIFICATION OPTIONS

product #: see charts below
edge finish: see page 9
worksurface finish: see page 9

ORDER EXAMPLE

product #: FB120-90WS.2334
edge finish: DT Dark Tone, E12
worksurface finish: Espresso, M10
grommet: GC (Rear Center)
grommet color: Cloud White

120° CORNER 90° ENDS

PART #	HEIGHT	A	B	C	D	PRICE
FB120-90WS.2334	1.25"	23"	34"	—	—	\$565
FB120-90WS.2340	1.25"	23"	40"	—	—	\$676
FB120-90WS.2346	1.25"	23"	46"	—	—	\$822

120° Corner / 120° Ends

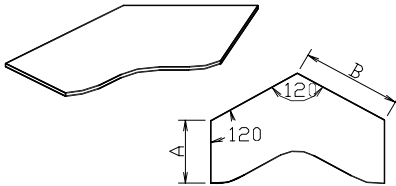

DESCRIPTION

Worksurface top only, for use with height adjustable base within workstation application

NOTES

- Add grommet (add \$75 list)
Specify GL, GC, GR
- Order base separately from MY-HITE pricebook

Note: Top size reduced 1" in depth and 2" in width to fit within system workstation and prevent pinch points. We do not recommend using full size worktop in paneled workstation applications.

SPECIFICATION OPTIONS

product #: see charts below
edge finish: see page 9
worksurface finish: see page 9

ORDER EXAMPLE

product #: FB120-120WS.2334
edge finish: DT Dark Tone, E12
worksurface finish: Espresso, M10
grommet: GC (Rear Center)

120° CORNER 120° ENDS

PART #	HEIGHT	A	B	C	D	PRICE
FB120-120WS.2334	1.25"	23"	34"	—	—	\$571
FB120-120WS.2340	1.25"	23"	40"	—	—	\$684
FB120-120WS.2346	1.25"	23"	46"	—	—	\$831